

# N5.230 CR2

## Specifications

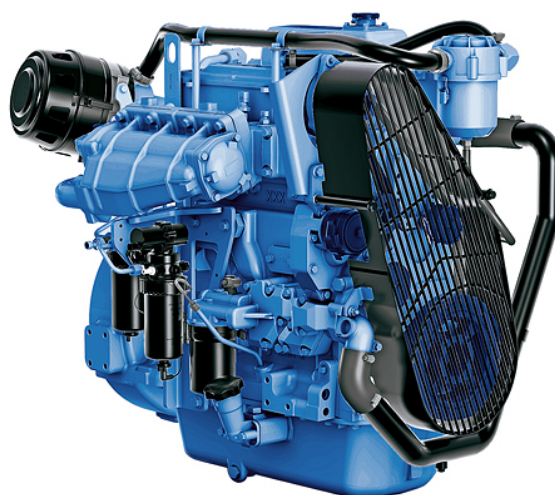

<b>Power at crankshaft</b>	168 kW [228 hp]	<b>Engine base</b>	John Deere
<b>Displacement</b>	4.5 l [276 in <sup>3</sup> ]	<b>Fuel system</b>	Direct injection High pressure Common Rail Electronically controlled
<b>Configuration</b>	4 cylinders in line 4 valves per cylinder	<b>Air intake</b>	Turbocharged Air-to-Coolant aftercooler
<b>Operation type</b>	4 stroke Diesel	<b>Cooling</b>	Closed cooling with heat exchanger
<b>Bore &amp; Stroke</b>	106.4 x 127 mm [4.19 x 5 in]	<b>Mounting angle</b>	12° Front up 0° Front down
<b>Compression ratio</b>	16.7:1	<b>Alternator</b>	24 Volt 50 Amp
<b>Rated speed</b>	2600 rpm	<b>Rating</b>	M4
<b>Idle speed</b>	600 rpm	<b>Emission compliance</b>	IMO Marpol Annex VI NRMM (97/68/EC) Tier 3 EPA marine Tier 3
<b>Peak torque</b>	714 Nm		
<b>Peak torque speed</b>	2100 rpm		
<b>Dry weight</b>	578 kg [1274 lb]		

# N5.230 CR2

168 kW [228 hp] @ 2600 rpm

## TECHNICAL DESCRIPTION

### Engine block

- Replaceable wet-type cylinder liners
- 4 valves per cylinder
- Watercooled exhaust manifold

### Fuel system

- Common Rail fuel injection system
- Fuel heater
- Primary & secondary fuel filter

### Lubrication system

- Replaceable full-flow oil filter
- Oil dipstick
- Oil cooler

### Cooling system

- Closed cooling with heat exchanger
- Gear driven self-priming raw water pump
- Coolant circulating pump
- Water cooled exhaust elbow

### Electrical system & Instrumentation

- 24V 50A alternator
- 24 Volt starter motor
- Complete instrumentation including key switch and alarms
- Extension cable harness with plug-in connection

### Air intake

- Turbocharged
- Air-to-Coolant aftercooler

### Other features

- Flywheel SAE 3
- Internal balancers
- Flexible engine mounting

### Optional equipment & accessories

- Keel cooling adaptation
- Dry exhaust elbow
- Complete marine propulsion systems
- Marine transmission adaptation kits
- Throttle and shift controls
- Additional instrumentation, Flying bridge extension harness
- Rigid engine mounting
- Power take off

## RATING

- Up to 3000 annual operating hours
- Load factor up to 40%
- Full power for no more than 1 hour out of each 12 hours of operation. The remaining operation time must be at or below cruising speed

## TRANSMISSIONS

### Shaft line

- ZF63A
- ZF63IV

Contact your local dealer for more details and availability for transmission model and type.

## PERFORMANCE CURVES

### Power at crankshaft

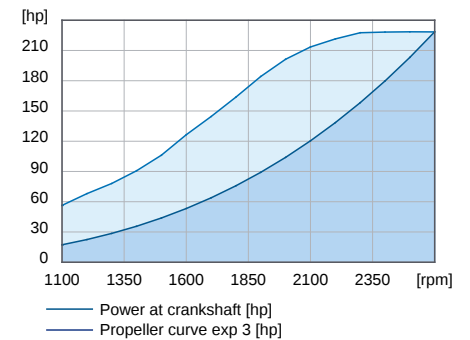

### Torque at crankshaft

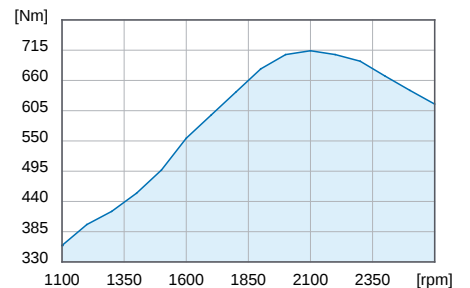

### Fuel consumption

At calculated propeller load exp 3

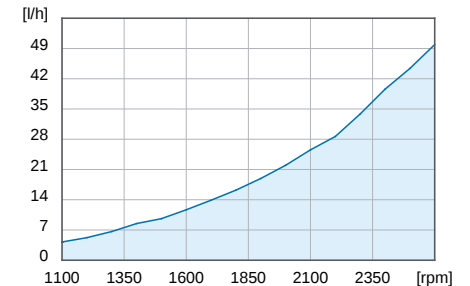

## DIMENSIONS BOBTAIL

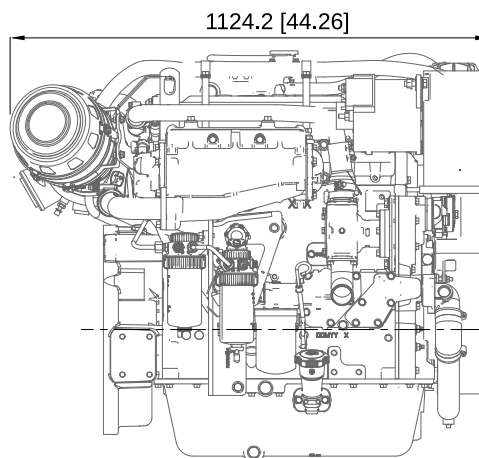
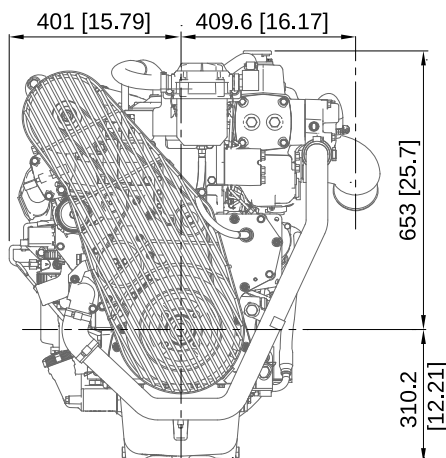

### Nanni Industries S.A.S. France

11, Avenue Mariotte - Zone Industrielle  
33260 La Teste - France  
Tel: +33 (0)5 56 22 30 60  
Fax: +33 (0)5 56 22 30 79

### Nanni Trading S.R.L

Via Degli Olmetti, 5/B  
00060 Formello (RM) - Italia  
Tel: +39 (0)6 30 88 42 51/52/53  
Fax: +39 (0)6 30 88 42 54

Technical data according to ISO 8665. Specifications are subject to change without notice. Images and illustrations may show non standard equipments. All combination of equipment & accessory are not available.

210715-ENG