

T4.230

Specifications

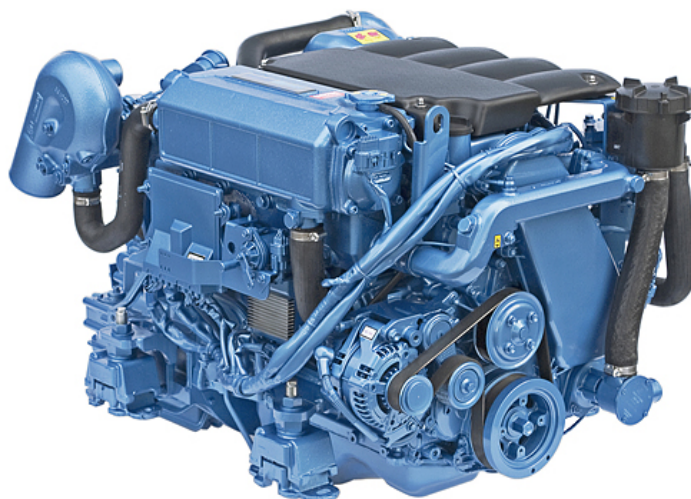

Power at crankshaft	169.1 kW [230 hp]	Engine base	Toyota
Displacement	2.982 l [182 in ³]	Fuel system	Direct injection High pressure Common Rail Electronically controlled
Configuration	4 cylinders in line 4 valves per cylinder	Air intake	Turbocharged with intercooler
Operation type	4 stroke Diesel	Cooling	Closed cooling with heat exchanger
Bore & Stroke	96 x 103 mm [3.78 x 4.06 in]	Mounting angle	7° Front up 7° Front down
Compression ratio	15:1	Alternator	12 Volt 100 Amp
Rated speed	3600 rpm	Rating	M6
Idle speed	700 rpm	Emission compliance	RCD 94/25/EC EPA marine Tier 3 BSO 2
Peak torque	573 Nm		
Peak torque speed	2000 rpm		
Dry weight	350 kg [771 lb]		

T4.230

169.1 kW [230 hp] @ 3600 rpm

TECHNICAL DESCRIPTION

Engine block

- 4 cylinders in line
- 4 valves per cylinder
- Dual overhead camshafts (DOHC)
- Watercooled exhaust manifold
- Internal balancers

Fuel system

- Common Rail fuel injection system
- Fuel filter with hand primer
- Integrated fuel cooler

Lubrication system

- Replaceable full-flow oil filter
- Oil dipstick
- Transmission oil cooler

Cooling system

- Closed cooling with heat exchanger
- Gear driven self-priming raw water pump
- Coolant circulating pump
- Water cooled exhaust elbow

Electrical system & Instrumentation

- 12V 100A alternator
- 12V Electrical system
- Complete instrumentation including key switch and alarms
- Extension cable harness with plug-in connection

Air intake

- Dry turbocharger
- Intercooler

Other features

- Flexible engine mounting

Optional equipment & accessories

- Complete marine propulsion systems
- Marine transmission adaptation kits
- Throttle and shift controls
- Additional instrumentation, Flying bridge extension harness
- Water boiler systems
- Complete fuel systems
- Complete exhaust systems
- Trolling valve

RATING

- Up to 500 annual operating hours
- Load factor up to 35%
- Full power for no more than 30 minutes out of each 8 hours of operation. The remaining operation time must be at or below cruising speed

TRANSMISSIONS

Shaft line

- TTM50A
- ZF45A
- ZF63A

Stern Drive

- Bravo X One
- Bravo X Three
- Bravo X Two

Contact your local dealer for more details and availability for transmission model and type.

PERFORMANCE CURVES

Power at crankshaft

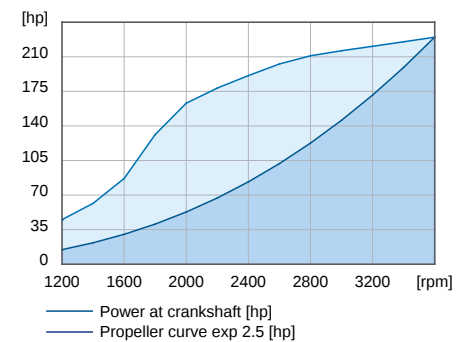

Torque at crankshaft

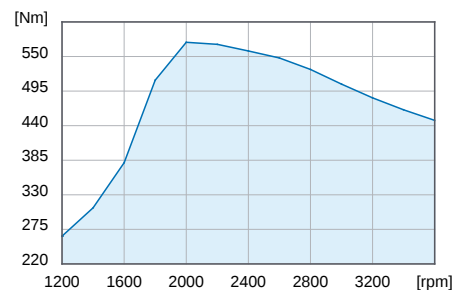

Fuel consumption

At calculated propeller load exp 2.5

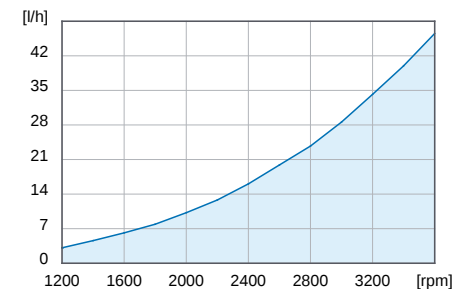

DIMENSIONS WITH TTM50A

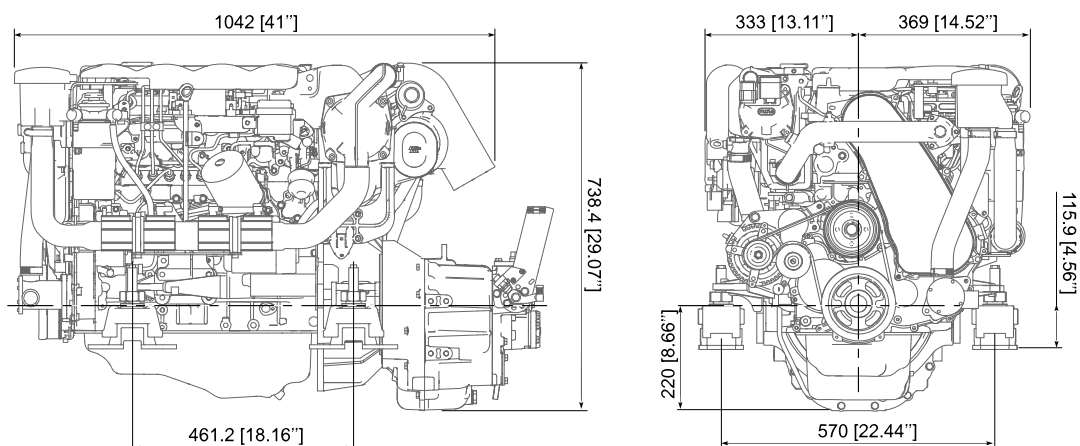

Nanni Industries S.A.S. France

11, Avenue Mariotte - Zone Industrielle
33260 La Teste - France
Tel: +33 (0)5 56 22 30 60
Fax: +33 (0)5 56 22 30 79

Nanni Trading S.R.L.

Via Degli Olmetti, 5/B
00060 Formello (RM) - Italia
Tel: +39 (0)6 30 88 42 51/52/53
Fax: +39 (0)6 30 88 42 54

Technical data according to ISO 8665. Specifications are subject to change without notice. Images and illustrations may show non standard equipments. All combination of equipment & accessory are not available.

120914-ENG