

# N4.85

## Specifications

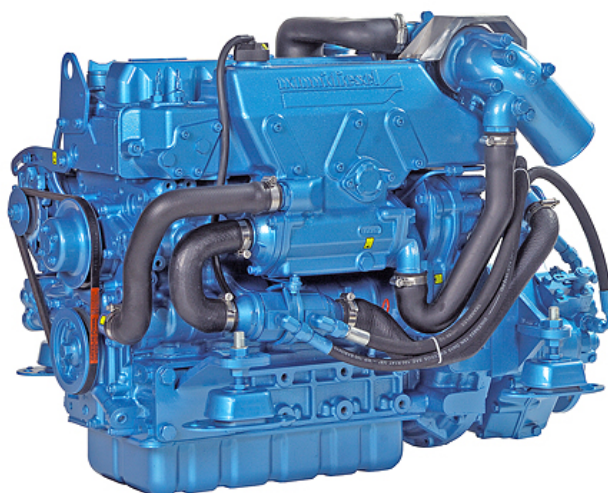

<b>Power at crankshaft</b>	62.5 kW [85 hp]	<b>Engine base</b>	Kubota
<b>Displacement</b>	3.053 l [186 in <sup>3</sup> ]	<b>Fuel system</b>	Mechanical direct injection
<b>Configuration</b>	4 cylinders in line 4 valves per cylinder	<b>Air intake</b>	Turbocharged
<b>Operation type</b>	4 stroke Diesel	<b>Cooling</b>	Closed cooling with heat exchanger
<b>Bore &amp; Stroke</b>	94 x 110 mm [3.7 x 4.33 in]	<b>Mounting angle</b>	7° Front up 7° Front down
<b>Compression ratio</b>	20:1	<b>Alternator</b>	12 Volt 100 Amp
<b>Rated speed</b>	2800 rpm	<b>Rating</b>	M4
<b>Idle speed</b>	875 rpm	<b>Emission compliance</b>	RCD 94/25/EC BSO 2
<b>Peak torque</b>	253 Nm		
<b>Peak torque speed</b>	1800 rpm		
<b>Dry weight</b> with TM345A	356 kg [784 lb]		

# N4.85

62.5 kW [85 hp] @ 2800 rpm

## TECHNICAL DESCRIPTION

### Engine block

- 4 cylinders in line
- 4 valves per cylinder
- Gear-driven valve train
- Watercooled exhaust manifold

### Fuel system

- Mechanical governor
- Cam driven in-line injection pump
- Fuel feed pump
- Fuel filter with hand primer

### Lubrication system

- Replaceable full-flow oil filter
- Oil dipstick
- Oil drain pump

### Cooling system

- Closed cooling with heat exchanger
- Gear driven self-priming raw water pump
- Coolant circulating pump
- Water cooled exhaust elbow

### Electrical system & Instrumentation

- 12V Electrical system
- 12V 100A alternator
- Electric starter motor
- Electric stop function
- Instrumentation panel, including Start/Stop, tachometer, coolant temperature & oil pressure indicators, alarms
- Extension cable harness with plug-in connection

### Air intake

- Turbocharger
- Mounted air cleaner

### Other features

- Flexible engine mounting
- Bracket for control cables

### Optional equipment & accessories

- Keel cooling adaptation
- Complete marine propulsion systems
- Throttle and shift controls
- Additional instrumentation, Flying bridge extension harness
- Engine mounting adaptation
- Two pole electrical system
- Water boiler systems
- SOLAS approved version
- Complete fuel systems
- Stuffing box connections
- Complete exhaust systems
- Trolling valve

## RATING

- Up to 3000 annual operating hours
- Load factor up to 40%
- Full power for no more than 1 hour out of each 12 hours of operation. The remaining operation time must be at or below cruising speed

## TRANSMISSIONS

### Shaft line

- TM345A
- TMC260
- TTMC5A
- ZF25A

Contact your local dealer for more details and availability for transmission model and type.

## PERFORMANCE CURVES

### Power at crankshaft

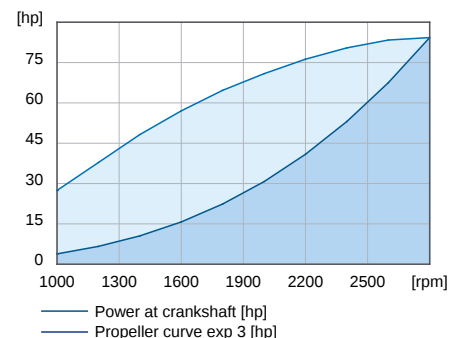

### Torque at crankshaft

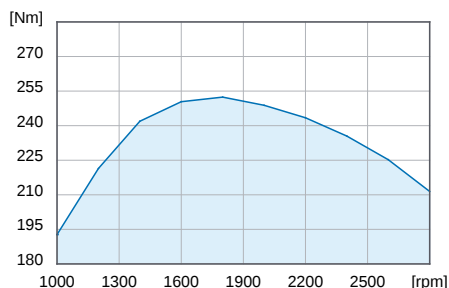

### Fuel consumption

At calculated propeller load exp 3

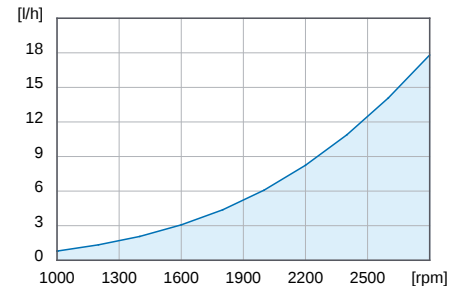

## DIMENSIONS WITH TM345A

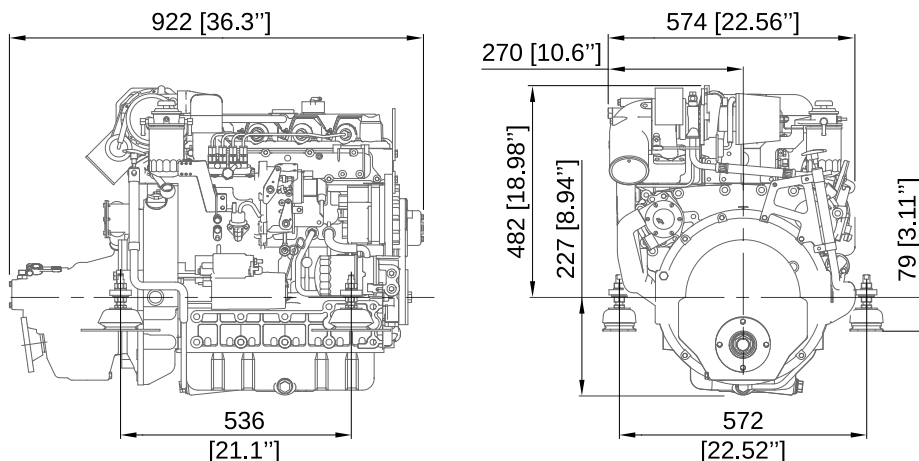

### Nanni Industries S.A.S. France

11, Avenue Mariotte - Zone Industrielle  
33260 La Teste - France  
Tel: +33 (0)5 56 22 30 60  
Fax: +33 (0)5 56 22 30 79

### Nanni Trading S.R.L.

Via Degli Olmetti, 5/B  
00060 Formello (RM) - Italia  
Tel: +39 (0)6 30 88 42 51/52/53  
Fax: +39 (0)6 30 88 42 54

Technical data according to ISO 8665. Specifications are subject to change without notice. Images and illustrations may show non standard equipments. All combination of equipment & accessory are not available.

120914-ENG