

ICOM INSTRUCTIONS

DESKTOP CHARGER

BC-162

PRECAUTIONS

⚠ DANGER! Charge the specified Icom batteries only. Only tested and approved for use with genuine Icom batteries. Fire and/or explosion may occur when a third party or counterfeit battery pack is charged.

⚠ USE INDOORS ONLY! NEVER expose the charger to rain, snow or any liquids.

⚠ CAUTION! NEVER insert battery pack (with/without the transceiver) in a wet or soiled condition into the charger. This may result in corrosion of the charger terminals or damage to the charger. The charger is not waterproof and water can easily get into it.

NEVER attempt to charge alkaline or dry cell batteries. They may burst causing damage and personal injury.

NEVER let metal, wire, etc. touch any internal part of the charger.

NEVER incinerate used batteries. This may cause an explosion.

NEVER use the charger when it is covered by objects which impede heat dispersal.

Information (U.S.A. only)



The Ni-Cd battery that you have purchased is recyclable. At the end of its life, under various state and local laws, it may be illegal to dispose of this battery into the municipal waste stream. Call 1-800-822-8837 for battery recycling options in your area or contact your dealer.

Thank you for purchasing the **BC-162** DESKTOP CHARGER. The BC-162 charges a Ni-Cd or a Li-ion battery pack in approx. 1-2 hrs.

Please read these instructions thoroughly before using the BC-162.

AVOID charging in conditions of extreme cold (under 0°C; +32°F) or extreme heat (over +45°C; +113°F). Batteries may not charge under extreme temperatures.

AVOID leaving the Li-ion battery pack in a fully charged, or completely discharged condition for long time. It causes shorter battery life. In case of leaving the battery pack unused for a long time, it must be kept safely after discharge, or use the battery until the battery indicator shows middle level.

Place the charger in a secure place to avoid inadvertent use by children.

Keep the charger away from TV sets or radios to prevent interference.

⚠ Make sure battery and charger contacts are always clean, otherwise batteries may not fully charge.

SAVE THESE INSTRUCTIONS! These instructions contain important safety and operating details for the **BC-162**.

CE Some versions of the BC-162 which display the "CE" symbol on the serial number comply with the essential requirements of the 89/336/EEC directive for Electromagnetic Compatibility. This compliance is based upon the harmonised CENELEC generic standard EN61000-3-2: 2001, EN61000-3-3+A1: 2001, EN61000-6-1: 2001 and EN61000-6-3: 2001.

PRECAUTIONS (continued)

To get the maximum life out of your Ni-Cd batteries:

1. Avoid overcharging— batteries must be removed from the charger to stop charging. Batteries should not be charged for more than 15 hours after the LED indicator turns green.
2. Use the batteries until they become almost completely exhausted under normal conditions.

⚠ If your batteries seem to have no capacity even after being fully charged, completely discharge them, then fully charge them again. If they still do not retain a charge (or very little), new batteries must be purchased.

Recommendation— Li-ion battery pack:

- Li-ion batteries are different from Ni-Cd batteries in that it is not necessary to completely charge and discharge them to prolong the battery life. Therefore, charging the battery in intervals, and not for extended periods is recommended.

SPECIFICATIONS

Dimensions : 86(W)×87.5(D)×75(H) mm
(proj. not incl.) 3³/₈(W)×3⁷/₁₆(D)×2³¹/₃₂(H) in.

Weight : Approx. 146 g; 5.2 oz

Charging temperature range:
0°C to 45°C; +32°F to +113°F

Power supply requirement:
12 to 20 V DC or the specified Icom AC adapter (BC-145S)

Charging current:

840 mA±10% (rapid charge)
30 mA±15 mA (trickle charge)

Electrostatic durability:

Air discharge 8 kV
Contact discharge 4 kV

All stated specifications are subject to change without notice or obligation.

Icom, Icom Inc. and the Icom logo are registered trademarks of Icom Incorporated (Japan) in the United States, United Kingdom, Germany, France, Spain, Russia and/or other countries.

Icom Inc.

1-1-32 Kamiminami, Hirano-ku, Osaka 547-0003, Japan.

Count on us!

A-6439D-1EX-①a Printed in Japan
© 2005-2011 Icom Inc.

CHARGING OPERATION

CAUTION

The transceiver power **MUST** be turned OFF during charging otherwise;

- The battery will not be charged correctly.
- The battery life may be shortened.

<For your information>

The transceiver's power may not be able to be turned OFF when the battery is exhausted. In such a case, remove the battery pack and charge the battery pack only.

NEVER insert battery pack (with/without the transceiver) in a wet or soiled condition into the charger.

CHARGE INDICATOR

- Lights orange while charging.
- Lights green when rapid charging is completed.
 - But it is still charging in trickle charge mode when charging a Ni-Cd battery pack.
- Flashes orange when the protector is activated.
 - Re-insert the battery pack (with/without the transceiver).
- Flashes red when the protector is activated.
 - The inserted battery pack or the charger has some problem.

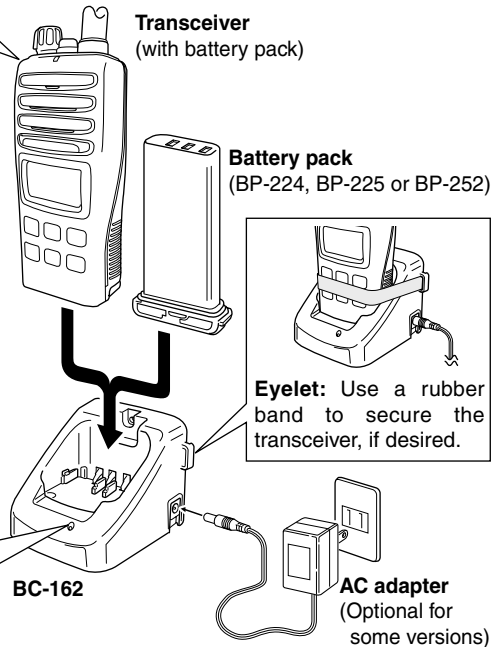

Eyelet: Use a rubber band to secure the transceiver, if desired.

• Approx. charging period

- BP-224 : 1 hours
- BP-225 : 1.5 hours
- BP-252 : 2 hours

*When the LED indicator does not light even after a battery pack is inserted properly, the battery pack may have some problem.

CHARGER INSTALLATION

The BC-162 can be installed onto a desktop or wall as illustrated at right.

• To a desktop

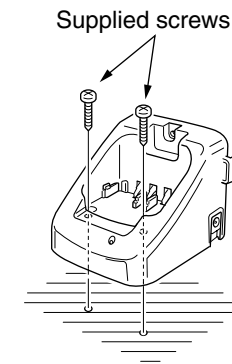

• To a wall

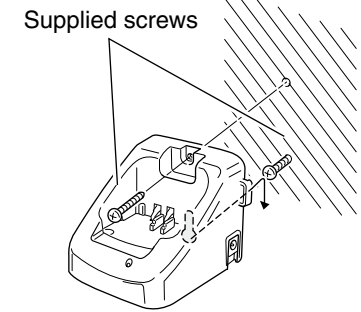

SUPPLIED ACCESSORIES

Item	Qty.
• AC adapter (BC-145S)*	1
• Screws (3.5×30).....	2

*Different type or no AC adapter is supplied with some versions.