EQUATOR

MSR0640

UNDERWATER
LIGHT



Registered Community Design

Operating Instructions

ASTEL MARINE

CONTENTS

Preface.....	3
Features.....	3
Precautions.....	3
Controls and Connectors.....	4
Installation.....	5
Appearance.....	7
Technical Specifications.....	7
Warranty.....	8
Declaration of Conformity.....	9



PREFACE

The EQUATOR MSR0640 series of a compact ultra-thin underwater light with built-in driver is designed to use the latest LED lighting technology.

The surface-mount designed casing enable very simple installation on the stern and both sides of the hull without making any bigger holes through the hull under waterline.

All the models are available in aluminium bronze casings. The lighting is available in white, blue or green colors with 6 power LEDs.

FEATURES

- Innovative and Patented Design
- Aluminium Bronze (AB2) Ultra-Thin Casing
- 6 Power LEDs Design
- White, Blue or Green Lighting
- High Grade Polycarbonate Glass Optical Window
- Vacuum Metalized Reflector
- Remote Control
- Digital Dimming
- Polarity Protection
- Transient Protection
- Thermal Protection
- Wide Range Power Supply
- Low Power Consumption
- Simple Installation

PRECAUTIONS

- The underwater light has to be installed and used in accordance with the instructions of this manual only.
- The power supply has to be disconnected before installation.
- The underwater light is recommended to be installed around 0.2 m below the waterline for the best illumination and to avoid overheating.
- Do not try to install or remove the underwater light while the vessel is in the water.
- The optical window has to be cleaned with a mild soap or detergent and lukewarm water by using a soft cloth or sponge. Do not use abrasive or highly alkaline cleaners. Never scrape with razor blades or other sharp instruments. Benzene, leaded gasoline, acetone or carbon tetrachloride should never be used.
- Do turn power off immediately and refer servicing to qualified service personnel if the underwater light does not operate normally following the operating instructions.

CONTROLS AND CONNECTORS

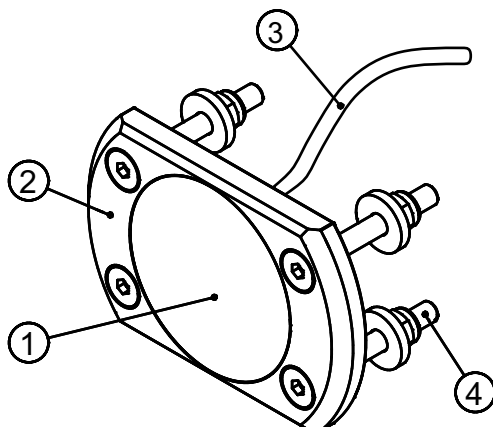

(1) Optical window

High-grade polycarbonate glass optical window.

(2) Underwater light casing

Aluminium bronze casing with fixing holes and cable gland.

(3) Cable

The 4-pole multi-core cable to connect the 12-24Vdc power supply and optional remote control or switch.

(4) Fixing screw

The fixing screws to fix the underwater light on the hull.

INSTALLATION

The underwater light kit consists of the following components:

- Underwater Light EQUATOR MSR0640
- 3 x fixing screw M6x80 with nut M6 and washer
- Operating Instructions with Declaration of Conformity and Warranty conditions

The EQUATOR MSR0640 has to be installed on a flat surface on the stern or both sides of the hull of the vessel.

Do not try to install the underwater light while the vessel is in the water.

When the installation is finished briefly test the underwater light prior to launching the vessel.

The installation have to be realized by a qualified personnel.

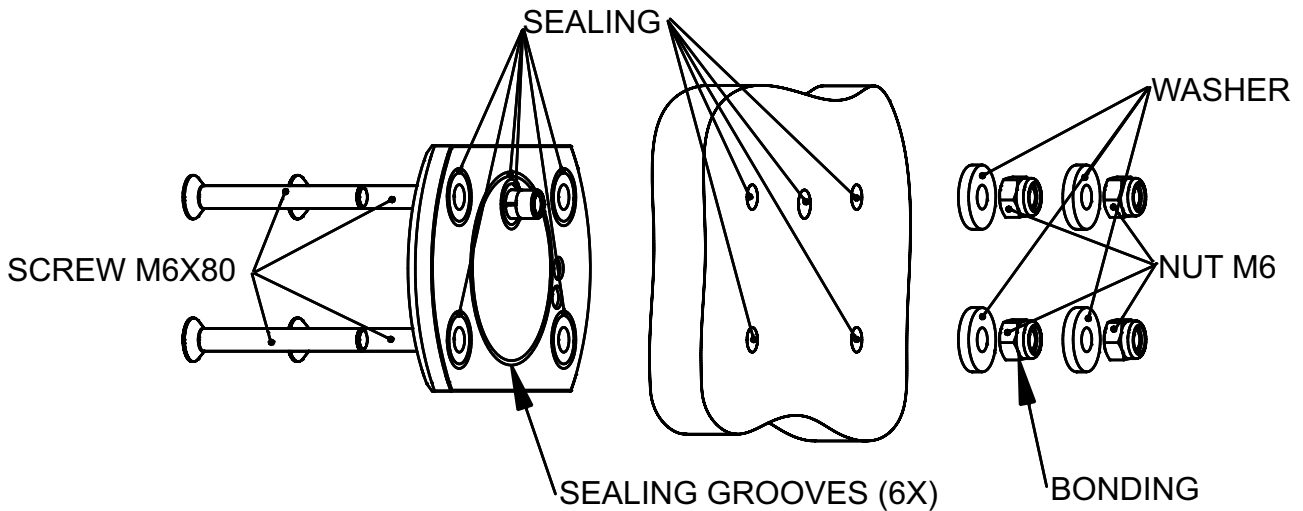

Note:

- **Avoid using the underwater light out of the water for more than 5 minutes.**
The underwater light is protected by a temperature sensor against over-heating. When the temperature of the underwater light exceeds 65°C the underwater light is automatically switched off.

Hull preparation

The underwater light is recommended to be installed around 0.2 m below the waterline for the best illumination and to avoid over-heating.

To fix the underwater light with screws M6x80 the diameter of holes drilled into the hull has to be 6 mm.

The diameter of the hole for cable gland drilled through the hull has to be 8 mm.

Sealing

Before inserting the cable with gland through the hole the sealant has to be used into the grooves, around the four fixing holes and around the gland in the rear surface of the underwater light.

The sealant has to be added to the exposed inner hole surface from the inside of the hull around the gland.

The sealant can be on silicon basis but the best solution is two-component polymer sealant.

Fixing

The cable with gland has to be inserted through the hole from outside of the hull.

The underwater light has to be fixed with three screws M6x80 with nuts M6 and washers.

Note:

- **All the stainless steel fixing screws (M6x80) it is highly recommended to be sealed in the contact with underwater light casing by optional TEF-GEL™ waterproof paste (not included) to prevent galvanic corrosion.**

Note:

- **To install the underwater light on the steel hull it is highly recommended to use the optional isolation board (not included) between the hull and underwater light casing to prevent galvanic corrosion.**

Note:

- **Do not overtighten the screws as this can result in hull or underwater light damage.**

Bonding

The underwater light has to be connected to the vessels bonding and cathodic protection using a pre-tinned wire a minimum of 8 AWG (8.36 mm²) with green insulation or green with a yellow stripe. The wire has to be connected to the underwater light by the help of one screw M6x80 and connected to that screw from the inside of the hull.

Note:

- **It is highly recommended to paint the entire underwater light casing exposed to the water with anti-foul paint.**
- **The optical window is protected with foil which has to be removed after anti-fouling process.**

Connection

The power supply has to be connected through the switch (not included) with correct polarity and protected by a fuse (not included). The power supply voltage has to be from 10 - 30Vdc.

Note:

- **The main DC power supply of the vessel has to be switched off before installation.**

The underwater light has to be connected as described in the table below:

EQUATOR MSR0640 wire colour	FUNCTION
Red	+ DC Power Supply
Black	GND Power Supply
Orange	+ Control
Brown	GND Control

Remote control connection

Remote control (optional) can be connected to turn-on and turn-off the underwater light and to control the luminosity.

To remotely turn-on and turn-off the underwater light the simple switch (not included) can be used and connected to the CONTROL wires by a 2-pole signal cable (not included).

Note:

- **If remote control is not used for normal operation the both CONTROL wires have to be bridged and insulated or connected to the GND.**

APPEARANCE

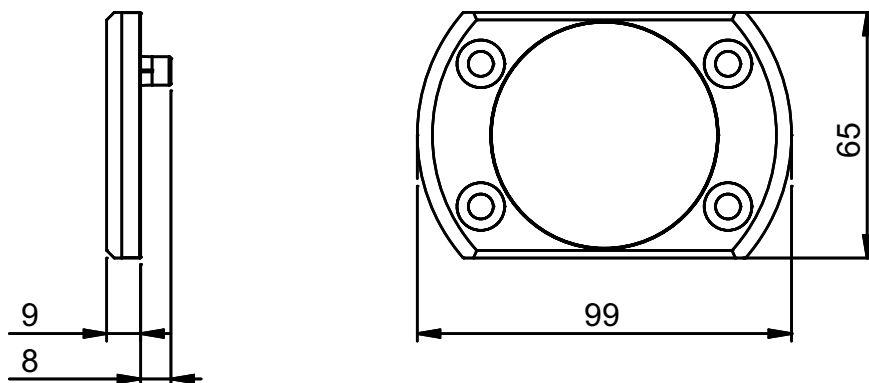

TECHNICAL SPECIFICATIONS

Power supply	12 – 24 Vdc, max. 680 mA/12 Vdc or 380 mA/24 Vdc
Lens angle	60°
Optical window	High-grade polycarbonate glass
Luminous flux	650 lm
White color temperature	6.000 - 10.000 K
Operating temperature	-10°C - +50°C
Casing	Aluminium bronze (AB2)
Protection	IP 68
Dimensions	99 x 65 x 9 mm
Weight	0.3 kg (bronze)

Design and specifications subject to change without notice.

WARRANTY

1. The equipment manufactured by ASTEL d.o.o. is warranted to be free from defects in workmanship and materials under normal use and service.
2. This Warranty is in effect for of two years from the date of purchase by the user. Proof of purchase must be included, to establish that it is inside the warranty period.
3. This Warranty is transferrable and covers the product for the specified time period.
4. In case any part of the equipment proves to be defective, other than those parts excluded in paragraph 5 below, the owner should do the following:
 - (a) prepare a detailed written statement of the nature and circumstances of the defect, to the best of the Owner's knowledge, including the date of purchase, the place of purchase, the name and address of the installer, and the Purchaser's name, address and telephone number;
 - (b) the Owner should return the defective part or unit along with the statement referenced in the preceding paragraph to the warrantor, ASTEL d.o.o., or an authorized distributor, postage/shipping prepaid and at the expense of the Purchaser;
 - (c) if upon the Warrantor's or authorized distributor's examination, the defect is determined to result from defective material or workmanship, the equipment will be repaired or replaced at the Warrantor's option without charge, and returned to the Purchaser at the Warrantor's expense;
 - (d) no refund of the purchase price will be granted to the Purchaser, unless the Warrantor is unable to remedy the defect after having a reasonable number of opportunities to do so. Prior to refund of the purchase price, Purchaser must submit a statement in writing from a professional boating equipment supplier that the installation instructions of the Operating Instructions manual have been complied with and that the defect remains;
 - (e) warranty service shall be performed only by the Warrantor, or an authorized distributor, and any attempt to remedy the defect by anyone else shall render this warranty void.
5. There shall be no warranty for defects or damages caused by faulty installation or hook-up, abuse or misuse of the equipment including exposure to excessive heat, salt or fresh water spray, or water immersion except for equipment specially designed as waterproof.
6. There shall be no responsibility or liability whatsoever on the part of the Warrantor or its employees and representatives for injury to any person or persons, or damage to property, loss of income or profit, or any other consequential or resulting damage or cost which may be claimed to have been incurred through the use or sale of the equipment, including any possible failure or malfunction of the equipment, or part thereof.
7. The Warrantor assumes no liability for incidental or consequential damages of any kind including damages arising from collision with other vessels or objects.

DECLARATION OF CONFORMITY

according to IEC Guide 22 and EN 45014

Manufacturer's Name: ASTEL, Podjetje za projektiranje, proizvodnjo in trgovino, d.o.o.

Manufacturer's Address: Dutovlje 138
6221 Dutovlje
Slovenija

declares that the products

Item, Product Name and Model Number: 1. Underwater Light EQUATOR MSR0640

conform to the following Product Specifications:

EMC: EN 55022 (CISPR 22: 1993)
EN 50130-4: 1994

Safety: EN 60950
EN 60529

Supplementary Information:

The products herewith comply with the requirements of the following Directives and carry the CE-marking accordingly:

- the EMC Directive 89/336/EEC
- the Safety Directive 73/23/EEC

ASTEL d.o.o.
Dutovlje 138
6221 Dutovlje
Slovenija

26th October, 2009

ASTEL d.o.o., Dutovlje 138, 6221 Dutovlje, Slovenia
Tel: +386 5 7310771, +386 5 7310772
Fax:+386 5 7310789
E-mail: info@astel-marine.com
Web: www.astel-marine.com