



Generating Set Nanni QLS47T

37.8 kW max at 1500 rpm

Engine base

- 4 strokes Diesel engine tested in all marine or industrial applications throughout the world.
- Tunnel type engine block. Off set steel pistons, hanger type crankcase and timing gear.

Injection and combustion system

- The Super Glow System comes as standard equipment to start the engine in cold temperatures.
- The E-CDIS injection system produces an ideal air/fuel mixture by creating three vortices in the combustion chamber. The combustion efficiency is improved, resulting in low fuel consumption.

Cooling system

- Cooling is ensured by heat exchange between coolant and seawater in an heat exchanger.
- Seawater pump with rubber impeller.

Generator

- Delivering a continuous power of 34.4 kW and able to provide up to 37.8 kW.
- IP21 protection (additional level available on demand).

Generator set ratings

Voltage (V)	Frequency (Hz)	Power * (kW)	
		max	cont.
400	50	37.8	34.4

Tri-phased output with power factor $\cos \phi = 0.8$

*Continuous (COP) and max (PRP) power rating according to ISO 8528-1

Weight and dimensions

Dry weight (kg)	561
Length (mm)	1331
Width (mm)	670
Height (mm)	835

Engine main features

- Kubota base Diesel engine
- 4 cylinders in line
- Closed cooling with heat exchanger

Generator main features

- Class H insulation
- 50 Hz
- Voltage accuracy of $\pm 1.5\%$
- Radio interference suppression
- Electronic regulator

Standard equipment

- Extension delivered by meter
- Closed cooling with heat exchanger
- Wet exhaust
- 12V Single-pole electrical system
- Safety shutdowns on low oil pressure and high coolant temperature
- Eco GE panel
- Rubber mounts
- Oil drain pump mounted on the engine

Optional equipment

- Seawater hoses
- Seawater filter
- Siphon breaker
- Fuel feed system piping
- Exhaust system
- Fuel prefilter
- Keel Cooling
- Vertical dry exhaust
- Horizontal dry exhaust
- Luxe GE panel (instead of Eco GE panel)
- Additional electric fuel feed. pump

Generator set QLS47T

Engine specifications

Engine base	Kubota
Cycle	4 strokes Diesel
Number of cylinders	4 in line
Displacement (cm ³)	3769
Bore and stroke (mm)	100 x 1200
Combustion system	Direct
Rated rpm	1500
Intake	Turbo

Fuel system

Fuel injection pressure (bar)	140
Fuel injection pump	In line, Bosch mini type
Fuel feed pump	Mechanical
Governor type	All speed mechanical

Cooling system

Seawater pump	Neoprene rotor
Coolant pump type	Coaxial alternator driven
Coolant capacity (l)	12
Exhaust manifold	Fresh water cooled
Exhaust elbow	Water injected

Lubrication system

Oil pan capacity (l)	13
Oil type	API-CF mini 15W40
Oil filter	Full flow type filter
Lubrication system	Forced by trochoid pump

Engine Electrical System

Engine alternator (V-A)	12 - 60
Battery recommended (Ah)	136
Starter motor (V-kW)	12 - 3

Instrument panel

Eco GE



Luxe GE



- Start and stop buttons
- Low oil pressure warning light
- Coolant temperature warning light
- Preheat warning light
- Battery charge warning light
- Oil pressure indicator *
- Coolant temperature indicator *

*Only on Luxe GE panel

Main components

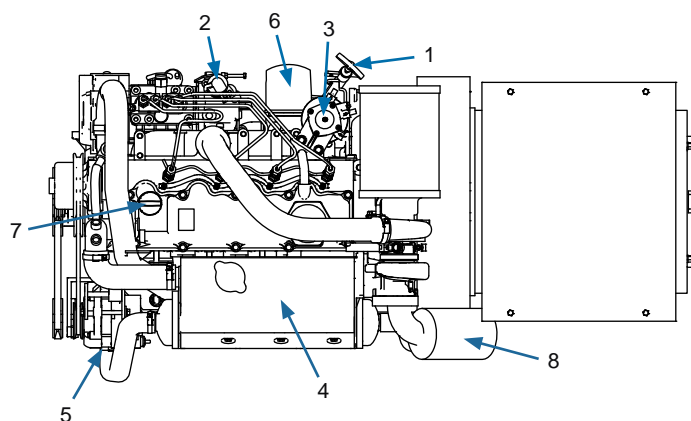

1. Oil drain pump.
2. Fuel feed pump
3. Fuel filter
4. Expansion tank
5. Seawater pump
6. Oil filter
7. Oil filler port
8. Exhaust elbow

Nanni Industries S.A.S. France
 11, Avenue Mariotte-Zone Industrielle
 33260 La Teste France
 Tel : + 33 (0)5 56 22 30 60
 Fax : +33 (0)5 56 22 30 79
www.nannidiesel.com

Certified



Your dealer