



# AC12N/AC42N

## Autopilot Computers

### Installation manual

ENGLISH



## Preface

As Navico is continuously improving this product, we retain the right to make changes to the product at any time which may not be reflected in this version of the manual. Please contact your nearest distributor if you require any further assistance.

It is the owner's sole responsibility to install and use a product from Navico in a manner that will not cause accidents, personal injury or property damage. The user of this product is solely responsible for observing safe boating practices.

NAVICO HOLDING AS AND ITS SUBSIDIARIES, BRANCHES AND AFFILIATES DISCLAIM ALL LIABILITY FOR ANY USE OF THIS PRODUCT IN A WAY THAT MAY CAUSE ACCIDENTS, DAMAGE OR THAT MAY VIOLATE THE LAW.

**Governing Language:** This statement, any instruction manuals, user guides and other information relating to the product (Documentation) may be translated to, or has been translated from, another language (Translation). In the event of a conflict between any Translation of the Documentation, the English language version of the Documentation will be the official version of the Documentation. This manual represents the product as at the time of printing.

## Warranty

The warranty card is supplied as a separate document. In case of queries, refer to the brand web sites: [www.bandg.com](http://www.bandg.com) and [www.simrad-yachting.com](http://www.simrad-yachting.com)

## Copyright

© Copyright 2012 by Navico Holding AS.

## About this manual

This manual is intended as a reference guide for installing and maintaining the AC12N and AC42N autopilot computers and other components in an autopilot system.

Please take time to read this manual to get a thorough understanding of the system components and their relationship to a complete autopilot system.

Important text that requires special attention from the reader is emphasized as follows:

→ **Note:** Used to draw the reader's attention to a comment or other important information.

 **Warning:** Used when necessary to warn personnel that they should proceed carefully to prevent risk of injury to personnel or damage to equipment.

# Contents

---

## **3 System description**

- 3 General
- 3 How to use this manual

## **4 Installation and wiring**

- 4 Installation checklist
- 4 Unpacking and handling
- 5 Determine system configuration
- 6 Autopilot system layout
- 7 Autopilot computer installation
- 9 Introduction to NMEA 2000 (SimNet)
- 11 Autopilot control units
- 12 Rudder feedback installation
- 13 Drive unit installation
- 16 Interfacing
- 17 External alarm

## **18 Spare parts**

## **19 Technical specifications**

- 19 Autopilot system
- 20 Autopilot computers

# 1

## System description

---

### General

The autopilot computer is a navigational data processing unit and contains the steering computer and electronics for the drive unit motor and clutch and provides an interface to other system components. Two models, AC12N (8 A continuous / 16 A peak motor current) and AC42N (30 A continuous / 50 A peak motor current) are available.

It communicates on the NMEA 2000 data and control network to establish a reliable digital communication and power distribution between the units in the autopilot system as well as other NMEA 2000 compatible products.

### How to use this manual

This manual is intended as a reference guide for installing the AC12N and AC42N autopilot computers and other components in an autopilot system.

Please take time to read this manual to get a thorough understanding of the system components and their relationship to a complete autopilot system.

The autopilot system includes an Operator manual. Refer to this manual for commissioning and sea trial of your autopilot system.

# 2

## Installation and wiring

---

An autopilot system interfaces with several units that are to be mounted in different locations on the boat, including:

- The boat's steering system
- The boat's electrical system (input power)
- Other equipment on board (NMEA 2000 interfacing)

In addition, the advanced capabilities of the system require the installer to perform a series of settings and tests to verify proper operation of the system, refer to the check list below.

### Installation checklist

1. Determine the system configuration you are installing (Page 5)
2. Perform the hardware installation (page 7)
3. Connect NMEA 2000 devices to network (page 9)
4. Perform Set-up (refer to Operator manual)
5. Test autopilot operation at sea (refer to sea trial instructions in the Operator manual).

### Unpacking and handling

Care should be taken when unpacking and handling the equipment. A visual inspection should be made to see that the equipment has not been damaged during shipment and that all components and parts are present according to the packing list.

An autopilot system will include:

- Control unit with accessories
  - Autopilot computer (AC12N or AC42N) with accessories.
- **Note:** The following parts are all part of an autopilot system, but will not necessarily be delivered with this autopilot computer (can be obtained separately).
- Compass (RC42N) with cable
  - Feedback unit (RF300 or RF25N) with transmission rod and cable
  - Appropriate drive unit for the installation (unless the autopilot is going to operate an existing drive unit or solenoids)
  - Optional equipment that may have been ordered for the installation.

## Determine system configuration

It is important to become familiar with the configuration of the system prior to beginning the installation. An example of a system featuring this autopilot computer is shown on the next page.

Plan your cabling and configure the NMEA 2000 network in accordance with the section on page 9. Pay particular attention to the autopilot computer/drive unit combinations.

As most of the units are communicating on a common network (NMEA 2000) with identical connectors, the installation is simple. Try to mount the units within the standard cable length supplied with each unit. Compatible drop, extension or converter cables should be available from your distributor.

## Autopilot system layout

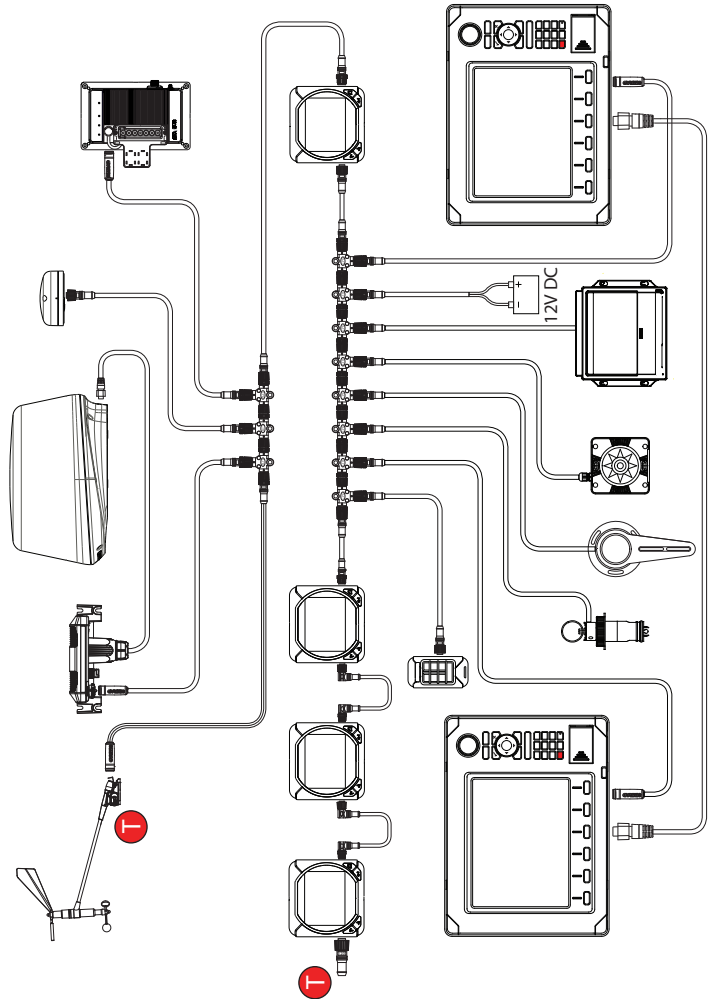

### → Notes:

- The backbone must be terminated at both ends. The wind sensor has a built-in terminator and can be used as one of the terminators
- Daisy-chaining, as shown in this illustration, is recommended for ease of installation. It will still be compatible with most NMEA 2000 devices but not fully comply with NMEA 2000 standard.

## Autopilot computer installation

The autopilot computer is designed to operate in a location with ambient temperatures below +55°C (+130°F).

- **Note:** The autopilot computer units (AC12N and AC42N) should be mounted vertically in a place between the control unit and the drive unit. The unit should not be exposed to dripping or splashing water.

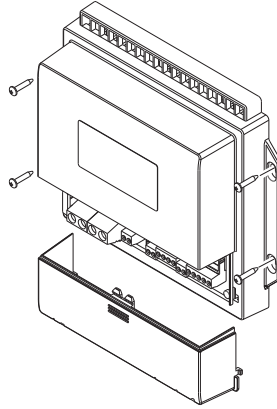

### Cabling

Use only shielded cables and ready made NMEA 2000 (or compatible) cables and accessories. This includes motor supply, drive unit cables and, if necessary, extension of the optional rudder feedback cable(s). The clutch/bypass cable and the solenoid cable should be 1.5 mm<sup>2</sup> (AWG14).

The motor supply cable and the drive unit motor cable should have sufficient wire gauge. This will minimize voltage drop and allow the drive unit to operate at full power.

Refer to the table below for recommended cable sizes.

Cable length	Drive unit voltage			
	12 V		24 V	
1. Breaker panel to autopilot computer. 2. Autopilot computer to drive unit motor (Length refers to each of the two cables)	AWG	mm <sup>2</sup>	AWG	mm <sup>2</sup>
Up to 3 m (10 ft.)	12	2.5	12	2.5
Up to 6 m (20 ft.)	10	4	10	2.5
Up to 10 m (32 ft.)	8	6	10	4
Up to 16 m (52 ft.)	6	10	8	6



Remove the bottom cover to get access to the plug-in terminals. Provide sufficient wire length so that the plug-in terminals can be easily connected and disconnected. Pull out each terminal before connecting the wires. Remove all strands before putting back the terminal cover.

A Micro-C NMEA 2000 cable is supplied with the autopilot computer. It has a connector in one end, and the other end is prepared for screw terminals.

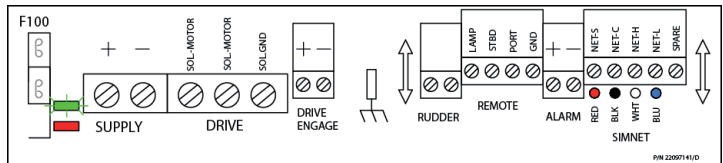
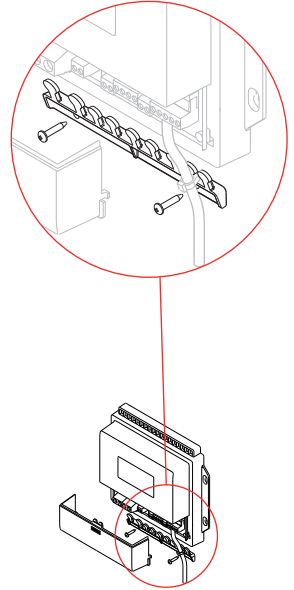

AC12N Board Terminals

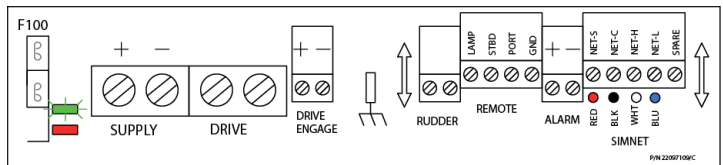

AC42N Board Terminals

➔ **Note:** White wire may be yellow on other compatible SimNet cable versions!

## Polarity protection

- **Note:** The fuse located in the lower left corner of the AC board is not put in its final position when supplied from factory. When the motor supply is connected to the terminal, a diode will light. If the light is red, you have to swap the wires. When the light is green, the polarity is correct. Switch off the supply voltage and put the fuse into the correct position.

## Radio Frequency Interference (RFI)

The autopilot system has excellent RFI protection as per EMC Directive 2004/108/EC.

NMEA 2000 (or compatible) cables and other signal cables (feedback, or others as required) should not be run in parallel with other cables carrying RF or high current, such as VHF and SSB transmitters, battery chargers/generators, winches and thrusters.

- **Note:** If problems occur with RFI, make provisions to connect the supply cable shield to the fast-on ground terminal. This terminal must also be connected to the hull bonding.

## Introduction to NMEA 2000 (SimNet)

NMEA 2000 is a combined electrical and data specification, and is based on CAN (Controller Area Network - SAE J1939) bus technology. NMEA 2000 permits exchange of data and commands between the interfaced products. NMEA 2000 stipulates the use of Micro-C and Mini-C hardware for the physical aspect of the network.

Most NMEA 2000 devices can be connected directly to the NMEA 2000 backbone and SimNet devices can be connected by using adapter cables.

## Essential network information

- NMEA 2000 is a powered network. It must have a separate 12-15 V DC power supply protected by a 5 Amp fuse. Do not connect the NMEA 2000 power cable to the same terminals as the start batteries, Autopilot Computer, Radar, thruster or other high current products
- An NMEA 2000 network consists of a linear “backbone” from which “drop cables” connect to the NMEA 2000 devices
- A single drop cable has a maximum length of 6 m (20 ft). The total length of all drop cables combined should not exceed 78 m (256 ft)
- An NMEA 2000 network has a maximum cable length of 100 m (328 ft) between any two points

- An NMEA 2000 network needs to have a terminator at each end of the backbone. A terminator can be one of the following:
  - a power cable with built in terminator
  - a terminated blanking plug
  - a wind transducer (terminator is in the mast head unit as opposed to the mast cable).
- Certain products have two Micro-C or SimNet connectors, which can be made to be an in-line component of the backbone. Connecting from device to device is known as 'daisy chaining'. This network topology is not officially NMEA 2000 compliant.

## Planning and installing a network backbone

Plan the backbone carefully.

The NMEA 2000 backbone needs to run between the locations of all products you want to install, typically in a bow to stern layout, and should be no further than 6 m from a device to be connected.

Choose from the following components to make up your NMEA 2000 backbone:

- Micro-C cables: Available lengths from 0.4 m (1.3 ft) to 25 m (82.5 ft)
- Micro-C power cables with or without termination
- T-connector: Use at locations where you want to connect a device by drop cable
- Wind transducer: If using a wind sensor, plan to connect this to one end of the backbone, as this has a built-in terminator
- Micro-C male and Micro-C female to SimNet adaptor cables for connecting to existing SimNet bus, or adding devices fitted with a SimNet connector to a Micro-C network.

## Power the network

An NMEA 2000 network requires its own 12 V DC power supply, protected by a 5 amp fuse or breaker.

In smaller NMEA 2000 systems, the power connection may be made anywhere in the system.

For larger systems, introduce power at a central point in the backbone to "balance" the voltage drop of the network. Use a power cable without termination.

- **Note:** When joining an NMEA 2000 network to a SimNet network, it is not necessary to introduce power to both.

- **Note:** Do not connect the power cable to the same terminals as the autopilot computer, pulse radar, bow thruster or other high current devices - the network may be affected by voltage drop when these devices are operated. Avoid connection to the engine starting batteries, where possible.

## Autopilot control units

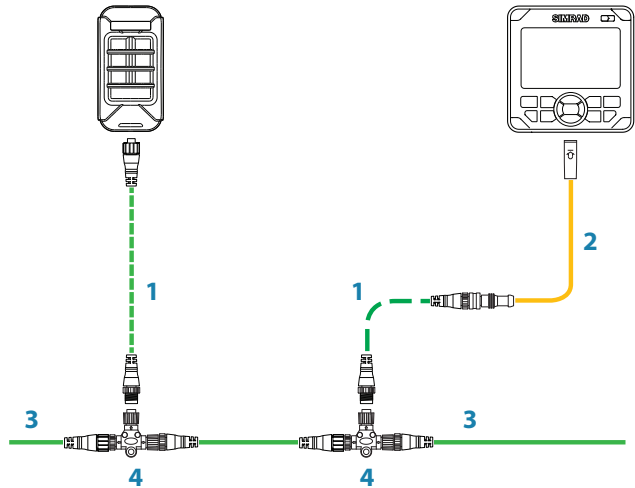

1. NMEA 2000 drop cable, male-female Micro-C plugs
2. SimNet to Micro-C (male) adapter cable (part no. 24005729)
3. NMEA 2000 backbone
4. Micro-C T-connectors

- **Note:** For more details, refer to the Autopilot Control unit's documentation.

## Rudder feedback installation

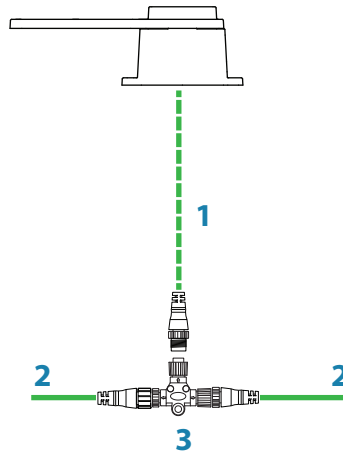

1. RF25N cable
2. NMEA 2000 backbone
3. Micro-C T-connector

→ **Note:** For more details, refer to the rudder feedback unit's documentation.

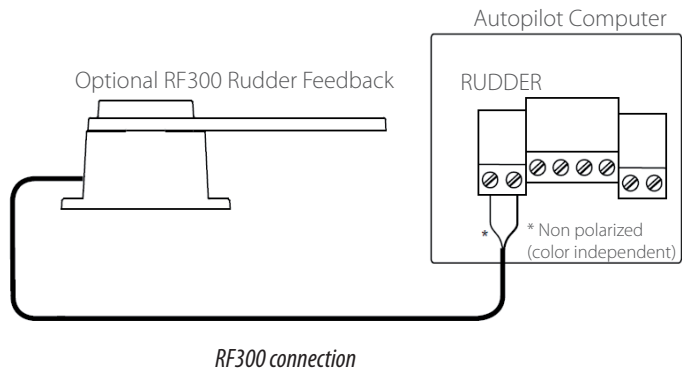

## Drive unit installation

The relations between drive units, drive unit voltage, autopilot computer, drive performance and interface to the steering gear are shown in the tables below.

Refer to the connecting diagram for the different drive units.

Installation instruction for the drive units are found in the manual for the individual units.

The maximum drive current capability of the AC12N and AC42N autopilot computers are different. Use the table below as reference and observe the notes.

### HYDRAULIC PUMPS:

MODEL	MOTOR VOLTS	AUTO-PILOT COMPUTER	RAM CAPACITY		FLOW RATE AT 10 bar cm <sup>3</sup> /min (cu. in./min)	MAX PRESSURE bar	POWER CONSUMPTION
			MIN cm <sup>3</sup> (cu. in.)	MAX cm <sup>3</sup> (cu. in.)			
RPU80	12V	AC12N	80 (4.9)	250 (15.2)	800 (49)	50	2.5-6 A
RPU160	12V	AC42N	160 (9.8)	550 (33.5)	1600 (98)	60	3-10 A
RPU300	12V	AC42N	290 (17.7)	960 (58.5)	3000 (183)	60	5-25 A
RPU300	24V	AC42N	290 (17.7)	960 (58.5)	3000 (183)	60	2.5-12 A

### LINEAR DRIVE UNITS:

MODEL	MOTOR VOLTS	AUTO-PILOT COMPUTER	MAX STROKE mm (in.)	PEAK THRUST kg (lb.)	MAX RUDDER TORQUE Nm (lb.in.)	HARD-OVER TIME sec. (30% load)	POWER CONSUMPTION	TILLER ARM mm (in.)
DD15	12V	AC42N	-	-	150 Kgm		2 A	-
HLD350	12V	AC12N	200 (7.9)	350 (770)	610 (5400)	12	2.5-8 A	175 (6.9)
HLD2000L	12V	AC42N	340 (13.4)	500 (1100)	1460 (12850)	19	3-10 A	298 (11.7)
HLD2000D	24V	AC42N	200 (7.9)	1050 (2310)	1800 (15900)	11	3-10 A	175 (6.9)
HLD2000LD	24V	AC42N	340 (13.4)	1050 (2310)	3180 (28000)	19	3-10 A	298 (11.7)
MSD50*	12V	AC12N	190 (7.5)	60 (132)	-	15	0.8-2 A	-
RAM-T1-12V	12V	AC42N	254 (10)	680 (1496)	1427 (12574)	16	2-4 A	214 (8.4)

MODEL	MOTOR VOLTS	AUTOPILOT COMPUTER	MAX STROKE mm (in.)	PEAK THRUST kg (lb.)	MAX RUDDER TORQUE Nm (lb.in.)	HARD-OVER TIME sec. (30% load)	POWER CONSUMPTION	TILLER ARM mm (in.)
RAM-T2-12V	12V	AC42N	254 (10)	680 (1496)	1427 (12630)	12	2-4 A	214 (8.4)
RAM-T2-24V	24V	AC42N	254 (10)	680 (1496)	1427 (12630)	12	2-4 A	214 (8.4)
RAM-T3-24V	24V	AC42N	305 (12)	1062 (2341)	2688 (23790)	15	2-4 A	257 (10.1)

Steering gear interface: Connects to quadrant or tiller.

\* For stern drive power assisted steering only.

1. For 12V drive units, the motor voltage is stepped down by the autopilot computer when operating from 24V supply.
2. The specified autopilot computer is necessary to achieve max drive unit capacity.
3. Recommended operational thrust or torque is 70% of listed peak value.
4. Typical average power consumption is 40% of listed maximum value.

## Connecting a reversible pump

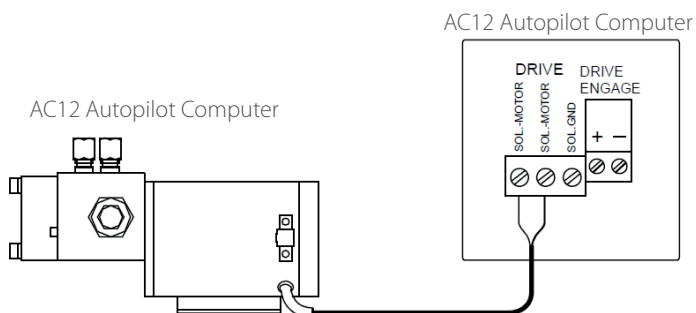

## Connecting a hydraulic linear drive

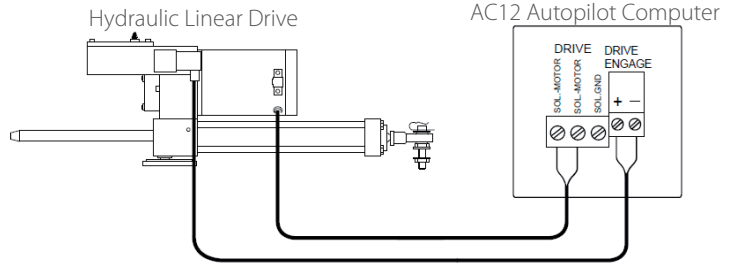

## Connecting a solenoid valve

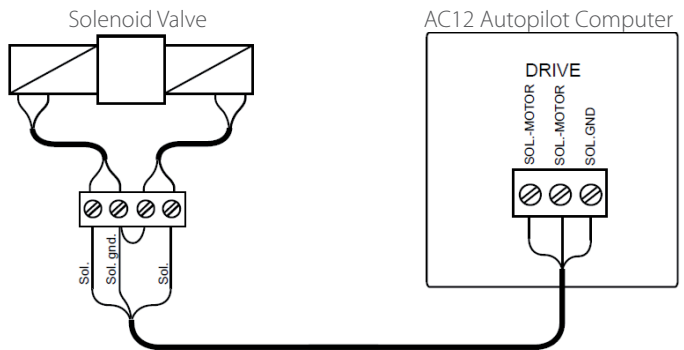



## Interfacing

With the autopilot system there are several possibilities to connect to other equipment for data collection and exchange:

1. NMEA 2000 device directly through Micro-C connectors and cables.
2. SimNet device via adapter cable, part no. 24005729.
3. NMEA 0183 via AT10 converter (+ adapter cable).

The different connecting diagrams on the following pages illustrate the interface possibilities of the autopilots.

### AT10 SimNet/NMEA 0183 converter

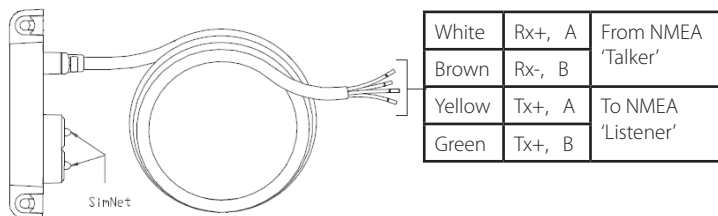

Data converted from SimNet/NMEA 2000 to NMEA 0183 (TX) and vice versa (RX).

NMEA 0183 sentence	TX (max rate [Hz])	RX
APB	0.5	x
BWC	0.5	x
BWR		x
DBT		x
DPT	0.5 1 <sup>1)</sup>	x
GGA		x
GLL	0.5 <sup>2)</sup>	x
HDG	4	x
HDM		x <sup>2)</sup>
HDT	4	x
HSC	0.1	
MTW	0.2	x
MWV Relative Wind	1	x
MWV True Wind	1	x
RMA		x

NMEA 0183 sentence	TX (max rate [Hz])	RX
RMB	0.5	x
RMC	0.5	x
RSA	3.33	
VHW	0.5	x
VTG	0.5	x
VLW	0.2 0.5 <sup>1)</sup>	x
VWR		x
WPL		x
XTE		x
ZDA	0.5	x
ZTG		x

Open cells indicates no transmission or reception.

<sup>1)</sup> Applies only for units with P/N - S/N code AA.

<sup>2)</sup> Applies for units with P/N - S/N code BA onwards.

## External alarm

The external alarm circuit has an open collector output for an external alarm relay or buzzer. The operating voltage for the circuit is the main supply voltage. Max. load on external alarm output is 0.75 Amp.

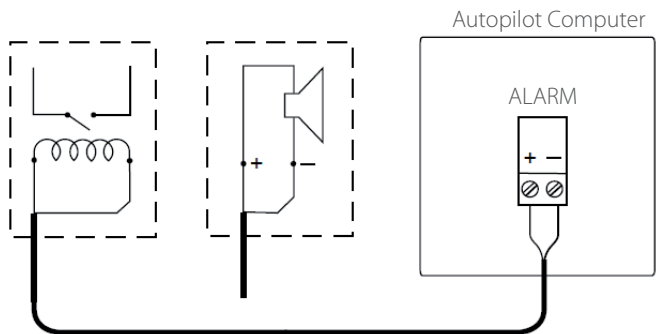

*External alarm connection*

# 3

## Spare parts

---

### Autopilot Computers

000-10866-001	AC12N Autopilot Computer
22097166	AC12N Installation accessories
000-10867-001	AC42N Autopilot Computer
22097125	AC42N Installation accessories
22096986	Terminal cover

### Other cables and accessories

24005729	SimNet cable to Micro-C. Adapter cable for SimNet products in an NMEA 2000 network.
24005936	AT10 Universal NMEA 0183 converter
24006694	AT10HD Heading NMEA 0183 converter
000-10611-001	Triton Autopilot Controller
000-10932-001	Simrad OP10 Autopilot Controller
000-10613-001	RC42N, Rate Compass, Micro-C
000-10614-001	Cable, Micro-C, right angle interconnect
000-10756-001	RF25N, Rudder feedback, 5 m, Micro-C
000-10760-001	Micro-C backbone kit, including: T-connector, 15 foot extension cable, 120 Ohm female terminator, 120 Ohm male terminator, Power node cable.

→ **Note:** New accessories are continuously being developed, check with your Simrad or B&G dealer or on the brand web sites: [www.simrad-yachting.com](http://www.simrad-yachting.com) or [www.bandg.com](http://www.bandg.com) for details on new products.

# 4

## Technical specifications

---

### Autopilot system

Boat type and size: .....Sail- and Motor boat (displacement and planning), up to 80 ft. \*

Steering system types:.....Hydraulic, Mechanical

Inter-unit connection:....NMEA 2000 (primary)/SimNet or NMEA 0183

Maximum number of products connected in a network: .....50

Supply voltage:.....See system units

Power consumption: .....Dependent on system configuration

EMC protection:.....CE IEC60945 Fourth edition 2002-08

Automatic Steering control:

Rudder Drive: .....Proportional rate or solenoid on/off

Parameter selection:..Automatic (Autotune) with manual override

Sea state control:.....Adaptive sea state filter or manual

Heading sensors:

Standard:.....RC42N Rate Compass

Options:.....FC40 Fluxgate compass

Rudder feedback units: .....RF25N, RF300 (optional), LF3000 (optional)

Alarms: .....Audible and visual, optional external

Alarm modes: .....Off course, system failures, overload

Steering modes:.....Standby (Off), Power steering, Auto, Nav, Wind,

Special Turn modes: .....Tack, Gybe

Course change: .....1 and 10 degrees push buttons

\* Depending on hull and steering type, displacement and drive type, it may steer boats up to approximately 110 ft.

→ **Note:** More detailed specifications can be found on the brand web sites [www.BandG.com](http://www.BandG.com) and [www.simrad-yachting.com](http://www.simrad-yachting.com)

Instrument data page interface:

Instrument screen	SimNet/NMEA 2000 PGN*
Heading	PGN 127250, PGN 130577
Rudder angle	PGN 127245
Speed	PGN 128259, PGN 129026, PGN 130577
Depth	PGN 128267
Wind angle, speed and direction	PGN 130306
Position	PGN 126992, PGN 127250, PGN 127258, PGN 129025, PGN 129026, PGN 129029, PGN 129033, PGN 130577
NAV	PGN 129283, PGN 129284, PGN 129285, PGN 129029, PGN 129291
Log	PGN 128275
Sea temperature	PGN 130310, PGN 130311

\* Parameter Group Number

## Autopilot computers

Dimensions:.....See page 21 and 22

Weight:

AC12N .....1.3 kg (2.9 lbs.)

AC42N .....2.8 kg (6.2 lbs.)

Material:..... Anodized aluminum and black ABS

Network supply and interface:.....9-16 V via SimNet/NMEA 2000

Supply voltage: AC12N/AC42N.....12-24 V DC

Power consumption: ..... 5 W (electronics), 0.5 W Network

Network load factor (NL):..... 1

Network ports (input/output): ..... 1

Clutch/bypass current:.....0.6 mA - 3 A

Reverse voltage indication:..... Yes

Motor / solenoid drive:

AC12N: .....8 A continuous, 16 A for 1 sec. peak

AC42N: ..... 30 A continuous, 50 A for 1 sec. peak

Heading Sensor input:SimNet/NMEA 2000 PGN 127250, PGN 130577

NFU Remote control input: ..... Yes

Rudder feedback input: .....SimNet/NMEA 2000 PGN 127245  
Optional rudder feedback input: ..... Frequency signal, 3400 Hz,  
20 Hz/deg.  
Solenoid output: .....AC12N only  
External Alarm:.....Open collector  
Temperature range:  
Operation:..... 0 to +55 °C (+32 to +130 °F)  
Storage:.....-30 to +70 °C (-22 to +158 °F)  
Mounting:..... Bulkhead mount

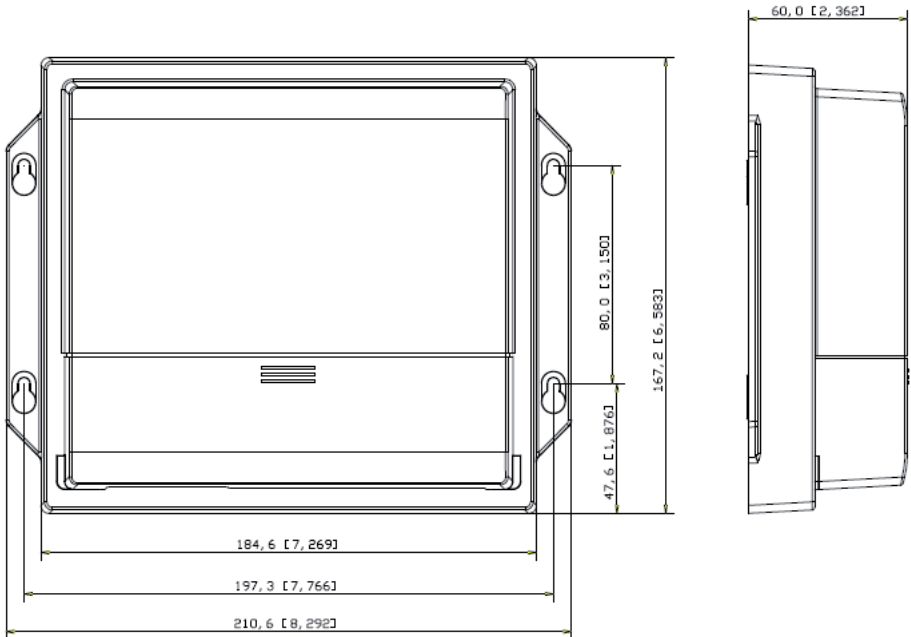

*AC12N Autopilot Computer - Dimensions*

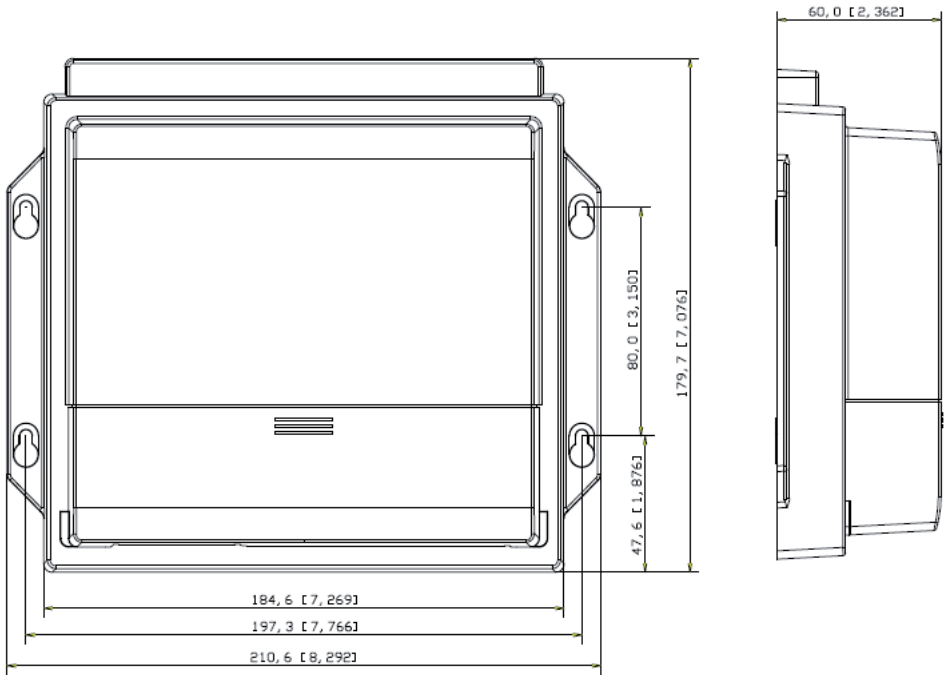

*AC42N Autopilot Computer - Dimensions*

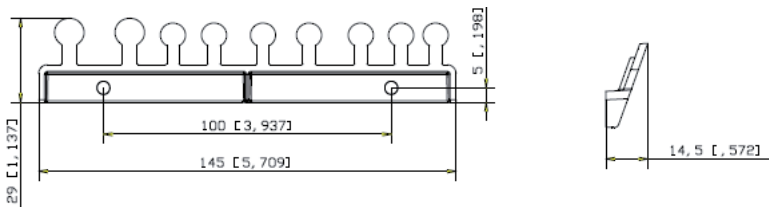

*AC12N/AC42N Cable retainer*



**SIMRAD**

**B&G**