

LOWRANCE®

ELITE T²

Installation Manual

ENGLISH



Preface

Disclaimer

As Navico is continuously improving this product, we retain the right to make changes to the product at any time which may not be reflected in this version of the manual. Please contact your nearest distributor if you require any further assistance.

It is the owner's sole responsibility to install and use the equipment in a manner that will not cause accidents, personal injury or property damage. The user of this product is solely responsible for observing maritime safety practices.

NAVICO HOLDING AS AND ITS SUBSIDIARIES, BRANCHES AND AFFILIATES DISCLAIM ALL LIABILITY FOR ANY USE OF THIS PRODUCT IN A WAY THAT MAY CAUSE ACCIDENTS, DAMAGE OR THAT MAY VIOLATE THE LAW.

This manual represents the product as at the time of printing. Navico Holding AS and its subsidiaries, branches and affiliates reserve the right to make changes to specifications without notice.

Governing language

This statement, any instruction manuals, user guides and other information relating to the product (Documentation) may be translated to, or has been translated from, another language (Translation). In the event of any conflict between any Translation of the Documentation, the English language version of the Documentation will be the official version of the Documentation.

Copyright

Copyright © 2018 Navico Holding AS.

Warranty

The warranty card is supplied as a separate document. In case of any queries, refer to the brand website of your unit or system:

Compliance statements

Europe

Navico declare under our sole responsibility that the product conforms with the requirements of:

- CE under RED 2014/53/EU

The relevant declaration of conformity is available in the product's section at the following website:

Countries of intended use in the EU

AT - Austria	LI - Liechtenstein
BE - Belgium	LT - Lithuania
BG - Bulgaria	LU - Luxembourg
CY - Cyprus	MT - Malta
CZ - Czech Republic	NL - Netherlands
DK - Denmark	NO - Norway
EE - Estonia	PL - Poland
FI - Finland	PT - Portugal
FR - France	RO - Romania
DE - Germany	SK - Slovak Republic
GR - Greece	SI - Slovenia
HU - Hungary	ES - Spain
IS - Iceland	SE - Sweden
IE - Ireland	CH - Switzerland
IT - Italy	TR - Turkey
LV - Latvia	UK - United Kingdom

United States of America

Navico declare under our sole responsibility that the product conforms with the requirements of:

- Part 15 of the FCC Rules. Operation is subject to the following two conditions: (1) this device may not cause harmful interference, and (2) this device must accept any interference received, including interference that may cause undesired operation

⚠ Warning: The user is cautioned that any changes or modifications not expressly approved by the party responsible for compliance could void the user's authority to operate the equipment.

→ **Note:** This equipment generates, uses and can radiate radio frequency energy and, if not installed and used in accordance with the instructions, may cause harmful interference to radio communications. However, there is no guarantee that the interference will not occur in a particular installation. If this equipment does cause harmful interference to radio or television reception, which can be determined by turning the equipment off and on, the user is encouraged to try to correct the interference by one or more of the following measures:

- Reorient or relocate the receiving antenna
- Increase the separation between the equipment and receiver
- Connect the equipment into an outlet on a circuit different from that of the receiver is connected
- Consult the dealer or an experienced technician for help

Industry Canada

This device complies with Industry Canada's license-exempt RSSs. Operation is subject to the following two conditions: (1) This device may not cause interference; and (2) This device must accept any interference, including interference that may cause undesired operation of the device.

Le présent appareil est conforme aux CNR d'Industrie Canada applicables aux appareils radio exempts de licence. L'exploitation est autorisée aux deux conditions suivantes: (1) l'appareil ne doit pas produire de brouillage, et. (2) l'utilisateur de l'appareil doit accepter tout brouillage radioélectrique subi, même si le brouillage est susceptible d'en compromettre le fonctionnement.

Industry Canada Statement: Under Industry Canada regulations, this radio transmitter may only operate using an antenna of a type and maximum (or lesser) gain approved for the transmitter by Industry Canada. To reduce potential radio interference to other users, the antenna type and its gain should be so chosen that the equivalent isotropically radiated power (e.i.r.p.) is not more than that necessary for successful communication.

Conformément à la réglementation d'Industrie Canada, le présent émetteur radio peut fonctionner avec une antenne d'un type et d'un gain maximal (ou inférieur) approuvé pour l'émetteur par Industrie Canada. Dans le but de réduire les risques de brouillage radioélectrique à l'intention des autres utilisateurs, il faut choisir le type d'antenne et son gain de sorte que la puissance isotrope rayonnée équivalente (p.i.r.e.) ne dépasse pas l'intensité nécessaire à l'établissement d'une communication satisfaisante.

Australia and New Zealand

Navico declare under our sole responsibility that the product conforms with the requirements of:

- level 2 devices of the Radiocommunications (Electromagnetic Compatibility) standard 2017
- radiocommunications (Short Range Devices) Standards 2014

Internet usage

Some features in this product use an internet connection to perform data downloads and uploads. Internet usage via a connected mobile/cell phone internet connection or a pay-per-MB type internet connection may require large data usage. Your service provider may charge you based on the amount of data you transfer. If you are unsure, contact your service provider to confirm rates and restrictions.

Trademarks

Navico[®] is a registered trademark of Navico Holding AS.

Lowrance[®] is a registered trademark of Navico Holding AS.

Bluetooth[®] is a registered trademark of Bluetooth SIG, Inc.

Einrude[®] is a registered trademark of BRP US, Inc.

Mercury[®] is a registered trademark of Mercury.

NMEA[®] and NMEA 2000[®] are registered trademarks of the National Marine Electronics Association.

Power-Pole[®] is a registered trademark of JL Marine Systems, Inc.

SD[™] and microSD[™] are trademarks or registered trademarks of SD-3C, LLC in the United States, other countries or both.

SmartCraft VesselView[®] is a registered trademark of Mercury.

Suzuki® is a registered trademark of Suzuki.

About this manual

This manual is a reference guide for installing units.

Some features may not be activated or available for screenshots in the manual. As a result, screenshots of menus and dialogs may not match the look of your unit.

Important text that requires special attention from the reader is emphasized as follows:

→ **Note:** Used to draw the reader's attention to a comment or some important information.

⚠ **Warning:** Used when it is necessary to warn personnel that they should proceed carefully to prevent risk of injury and/or damage to equipment/personnel.

Contents

11 Introduction

- 11 Parts included
- 12 Keys
- 13 Card reader
- 14 Connectors

15 Installation

- 15 Installation guidelines
- 16 Quick release bracket mounting
- 17 U-bracket mounting
- 18 Panel mounting

19 Wiring

- 19 Connectors
- 19 Wiring guidelines
- 20 Power and NMEA 0183
- 23 Sonar
- 23 NMEA 2000

26 Software setup

- 26 First time startup
- 26 Software setup sequence
- 26 Turning the system on and off
- 27 Touchscreen calibration
- 27 The settings dialog
- 27 System settings
- 28 Alarms
- 29 Sonar settings
- 33 Autopilot settings
- 33 Fuel settings
- 36 Wireless settings
- 37 Network settings

41 3rd party support

- 41 SmartCraft VesselView integration
- 41 Suzuki engine integration
- 41 Yamaha engine integration
- 42 Evinrude engine integration

42 Power-Pole anchors

43 Accessories

44 Supported data

44 NMEA 2000 compliant PGN List

49 NMEA 0183 supported sentences

51 Technical specifications

51 Elite Ti²

53 Dimensional drawings

53 ELITE 7Ti²

53 ELITE 9Ti²

54 ELITE 12Ti²

1

Introduction

Parts included

ELITE Ti²

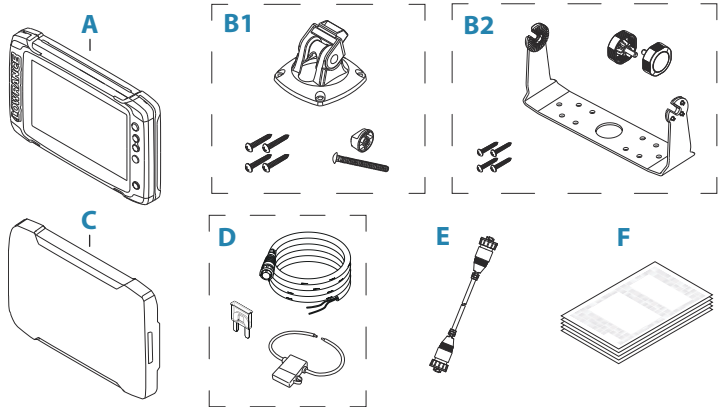

- A** ELITE Ti² unit
- B1** ELITE 7Ti² quick release bracket kit
- B2** ELITE 9Ti² and 12Ti² u-bracket kit
- C** Sun cover
- D** Power cable kit
- E** 7-pin to 9-pin transducer adapter cable (Included with units that do not ship with a transducer)
- F** Documentation pack

Keys

ELITE Ti²

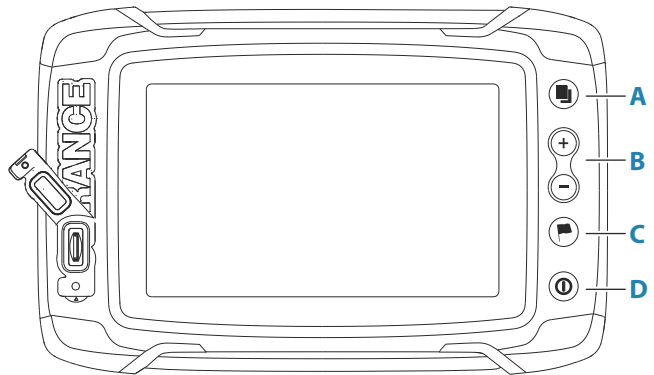

A Pages key

- Press once to activate the home page, repeat short presses to cycle the favorite pages

B Zoom Out / Zoom In keys and MOB key

- Press to zoom in and out
- Simultaneous press both keys to save a Man Overboard (MOB) waypoint at the current vessel position

C Waypoint key

- Press to open the new waypoint dialog
- Press twice to save a waypoint
- Press and hold to access the find dialog.

D Power key

- Press to turn the unit ON
- Press and hold to turn the unit OFF
- When ON press once to display the System Controls dialog, repeat short presses to cycle the backlight brightness

Card reader

A memory card can be used for:

- Chart data
- Software updates
- Transfer of user data
- System backup

→ **Note:** Do not download, transfer or copy files to a chart card. Doing so can damage chart information on the chart card.

The protective door should always be securely shut immediately after inserting or removing a card, in order to prevent possible water ingress.

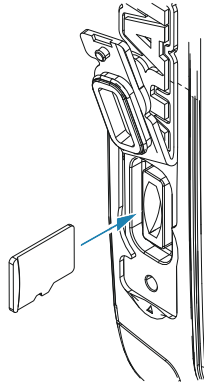

Connectors

ELITE Ti²

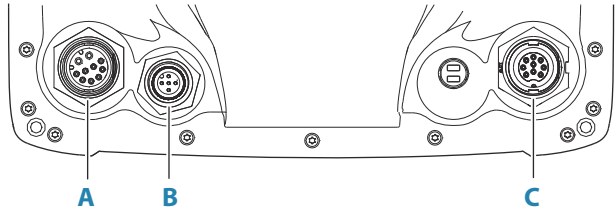

A Power and NMEA 0183

The NMEA 0183 functionality requires a combined Power and NMEA 0183 cable (sold separately)

B NMEA 2000

C Sonar

2

Installation

Installation guidelines

Choose the mounting location carefully, make sure that there are no hidden electrical wires or other parts behind the panel before you drill or cut. Ensure that any holes cut are in a safe position and will not weaken the boat's structure. If in doubt, consult a qualified boat builder, or marine electronics installer.

Don't:

- Mount any part where it can be used as a hand hold
- Mount any part where it might be submerged
- Mount any part where it will interfere with the operation, launching, or retrieving of the boat

Do:

- Test the unit in its intended location to ensure satisfactory wireless and GPS performance. Metal and carbon materials are known to impact the performance in a negative way. A well placed external GPS source and/or wireless module can be added to overcome poor performance
- Consider the optimum viewing angles
- Consider the overall width and height requirements
- Consider access to the card reader
- Leave sufficient clearance to connect all relevant cables
- Check that it is possible to route cables to the intended mounting location

→ **Note:** Where flush mounted, the enclosure should be dry and well ventilated. In small enclosures, it may be required to fit forced cooling.

⚠ Warning: Inadequate ventilation and subsequent overheating of the unit may cause unreliable operation and reduced service life. Exposing the unit to conditions that exceeds the specifications could invalidate your warranty. Refer to the technical specifications in the "*Technical specifications*" on page 51.

Quick release bracket mounting

1. Place the bracket in the desired mounting location. Ensure that the chosen location has enough height to accommodate the unit fitted in the bracket, and allows tilting of the unit.
2. Mark the screw locations using the bracket as a template, and drill pilot holes. Use fasteners suited to the mounting surface material.
3. Screw down the bracket.
4. Snap the unit to the bracket.
5. Set the desired angle and then insert the locking bolt and knob. Tighten to stop angle movement.

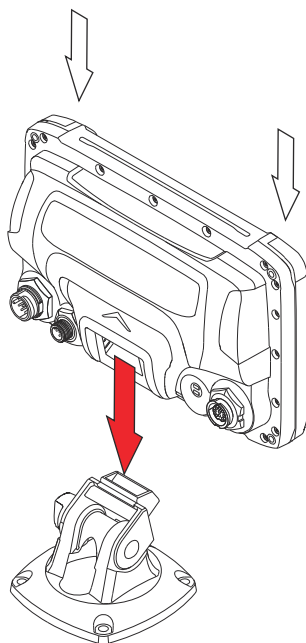

Removing the unit from the bracket

Pull and hold the release handle and then pull the unit from the bracket.

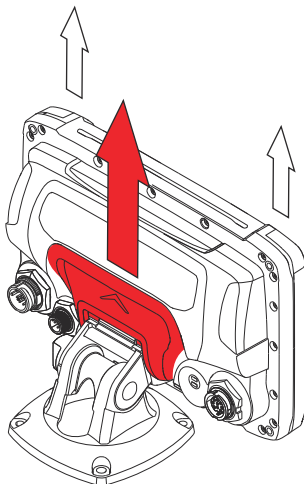

U-bracket mounting

1. Place the bracket in the desired mounting location. Ensure that the chosen location has enough height to accommodate the unit fitted in the bracket, and allows tilting of the unit. Also adequate space is required on both sides to allow tightening and loosening of the knobs.
2. Mark the screw locations using the bracket as a template, and drill pilot holes. Use fasteners suited to the mounting surface material.
3. Screw down the bracket.
4. Mount the unit to the bracket using the knobs. Hand tighten only.

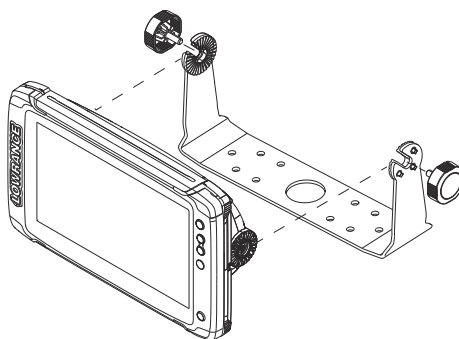

Panel mounting

Refer to the separate mounting template for panel mounting instructions.

Removing the corner clips

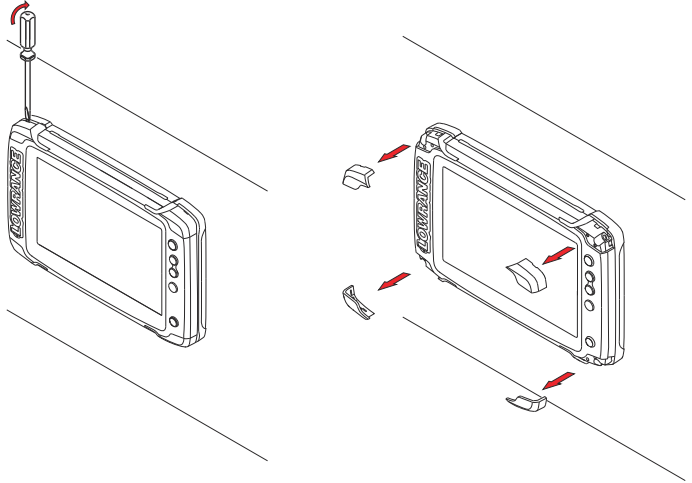

3

Wiring

Connectors

For available connectors and connector layout refer to "*Connectors*" on page 14.

Wiring guidelines

Don't:

- Make sharp bends in the cables
- Run cables in a way that allows water to flow down into the connectors
- Run the data cables adjacent to radar, transmitter, or large/high current carrying cables or high frequency signal cables.
- Run cables so they interfere with mechanical systems
- Run cables over sharp edges or burrs

Do:

- Make drip and service loops
- Use cable-tie on all cables to keep them secure
- Solder/crimp and insulate all wiring connections if extending or shortening the cables. Extending cables should be done with suitable crimp connectors or solder and heat shrink. Keep joins as high as possible to minimize possibility of water immersion.
- Leave room adjacent to connectors to ease plugging and unplugging of cables

⚠ Warning: Before starting the installation, be sure to turn electrical power off. If power is left on or turned on during the installation, fire, electrical shock, or other serious injury may occur. Be sure that the voltage of the power supply is compatible with the unit.

⚠ Warning: The positive supply wire (red) should always be connected to (+) DC with a fuse or a circuit breaker (closest available to fuse rating).

Power and NMEA 0183

Connector details

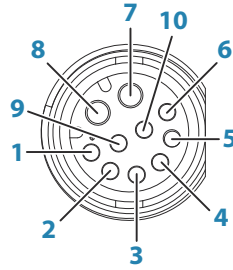

Unit socket (female)

Pin	Purpose
1	Not used
2	Listener B (Rx_B)
3	Not used
4	Talker B (Tx_B)
5	Drain
6	Talker A (Tx_A)
7	+ 12 V DC
8	DC negative
9	Not used
10	Listener A (Rx_A)

→ **Note:** To use the NMEA 0183 functionality a combined Power and NMEA 0183 cable must be used (sold separately).

Power

The unit is designed to be powered by 12 V DC.

It is protected against reverse polarity, under voltage and over voltage (for a limited duration).

A fuse or circuit breaker should be fitted to the positive supply. For recommended fuse rating, refer to "*Technical specifications*" on page 51.

Touchscreen operation in a non-marine environment

The unit is designed for operation on a vessel in the water. If you experience any difficulties operating the touch screen with the vessel out of the water, try the below fixes:

- If battery powered, try to power the unit from an AC to DC 12 V power supply
- Connect an additional cable, like a transducer, to the unit and run that cable to the floor
- Touch one of the cables connected to the unit (12 V power or transducer) to improve the electrical reference for the touch screen

NMEA 0183

The unit has a built in NMEA 0183 serial interface, providing both input and output. The port(s) uses the NMEA 0183 (serial balanced) standard, and can be configured in the software for different baud rates up to 38,400 baud.

Talkers and listeners

Only one talker (output device) can be connected to a serial input (RX) on the unit, in accordance with the NMEA0183 protocol. However, an output port (TX) on the unit may be connected to up to three listener (receiver) devices, dependent on the hardware capabilities of the receiver.

Power connection (included cable)

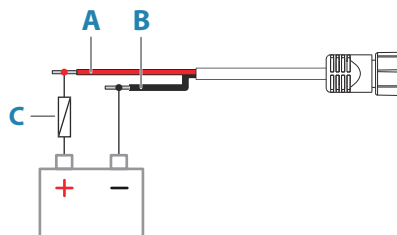

Key	Purpose	Color
A	+ 12 V DC	Red
B	DC negative	Black
C	Fuse	

Power and NEMA 0183 connection (cable sold separately)

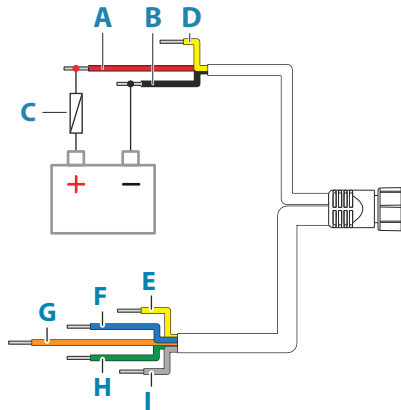

Pin	Description	Color
A	+ 12 V DC	Red
B	DC negative	Black
C	Fuse	--
D	Not used	Yellow
E	Talker A (Tx_A)	Yellow
F	Talker B (Tx_B)	Blue
G	Listener A (Rx_A)	Orange
H	Listener B (Rx_B)	Green
I	Ground (shield)	--

Sonar

Supports:

- Sonar / CHIRP Sonar
- DownScan
- SideScan
- Active Imaging/Active Imaging 3-in-1/TotalScan/StructureScan

→ **Note:** A 7-pin transducer cable can be connected to a 9-pin port using a 7-pin to 9-pin adaptor cable. However, if the transducer has a paddle wheel speed sensor, the water-speed data will not be displayed on the unit.

NMEA 2000

The NMEA 2000 data port allows receiving and sharing of a multitude of data from various sources.

Connector details

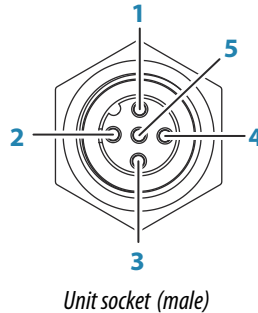

Pin	Purpose
1	Shield
2	NET-S (+12 V DC)
3	NET-C (DC negative)
4	NET-H
5	NET-L

Plan and install an NMEA 2000 network

An NMEA 2000 network consists of a powered backbone from which drop cables connect to NMEA 2000 devices. The backbone needs to run within 6 m (20 ft) of the locations of all products to be connected, typically in a bow to stern layout.

The following guidelines apply:

- The total length of the backbone should not exceed 100 meters (328 ft)
- A single drop cable has a maximum length of 6 meters (20 ft). The total length of all drop cables combined should not exceed 78 meters (256 ft)
- The backbone needs to have a terminator at each end of the backbone. The terminator can be a terminator plug or a unit with built-in terminator

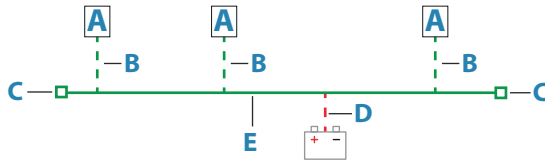

- A** NMEA 2000 device
- B** Drop-cable
- C** Terminator
- D** Power supply
- E** Backbone

Powering the network

The network requires its own 12 V DC power supply, protected by a 3 amp fuse.

For smaller systems: connect power at any location in the backbone.

For larger systems: connect power at a central point in the backbone to balance the voltage drop of the network. Make the installation such that the load/current draw on each side of the power node is equal.

→ **Note:** 1 LEN (Load Equivalency Number) equals 50 mA current draw.

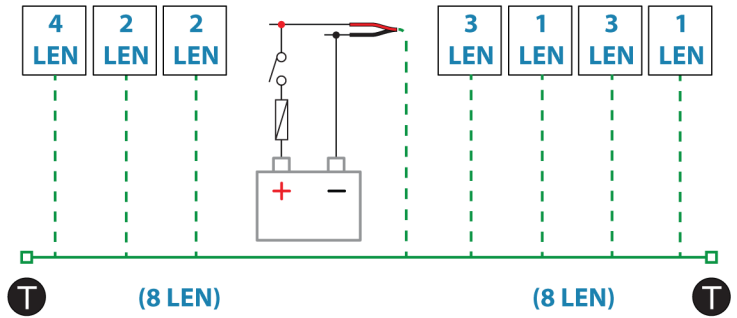

→ **Note:** Do not connect the NMEA 2000 power cable to the same terminals as the engine start batteries, autopilot computer, bow thruster or other high current devices.

4

Software setup

First time startup

When the unit is started for the first time, or after a factory default, the unit displays a series of dialogs. Respond to the dialog prompts to make fundamental settings.

You can perform further setup and later change settings using the system settings dialogs.

Software setup sequence

- 1 General settings** - refer to "*System settings*" on page 27.
 - Make general settings as desired
- 2 Advanced settings** - refer to "*Advanced*" on page 28.
 - Enable or disable features
 - Review the advanced setting options and make changes as desired
- 3 Source selection** - refer to "*Network settings*" on page 37.
 - Make sure that the proper external data sources have been selected
- 4 Wireless settings** - refer to "*Wireless settings*" on page 36.
 - Pair the Elite Ti² with another Elite Ti² to share data and sonar sources.
- 5 Feature setup**
 - Configure specific features as described later in this chapter

Turning the system on and off

The system is turned on by pressing the Power key.

Press and hold the Power key to turn the unit off.

You can also turn the unit off from the System Controls dialog.

If the Power key is released before the shut-down is completed, the power off process is cancelled.

Touchscreen calibration

→ **Note:** Ensure the screen is clean and dry before doing the calibration. Do not touch the screen unless prompted to do so.

In some cases it may be required to re-calibrate the touch screen. To re-calibrate your touchscreen, do the following:

1. Turn the unit off
2. Press and hold the waypoint key, and turn the unit on
3. Continue pressing the waypoint key during power on until the calibration utility screen comes up
4. Follow the instructions on the screen to perform the calibration.

When completed, the unit returns to the application screen.

The settings dialog

The software setup is done from the settings dialog.

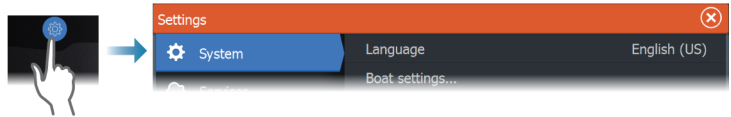

System settings

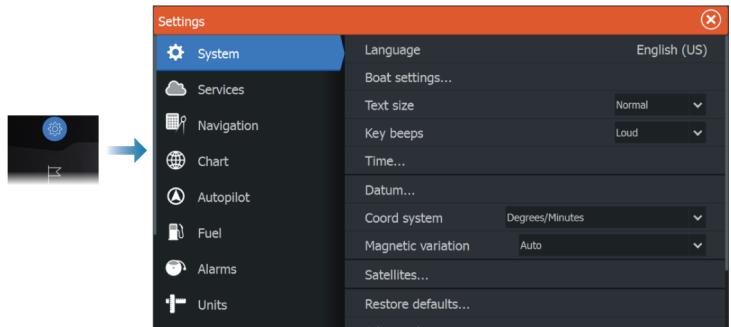

Boat settings

Used to specify the physical attributes of the boat.

Time

Controls the local time zone offset, and the format of the time and date.

Advanced

Used for configuration of advanced settings and how your system displays various user interface information.

Enabling or disabling features

Use the feature option to enable or disable features that are not automatically enabled or disabled by the system.

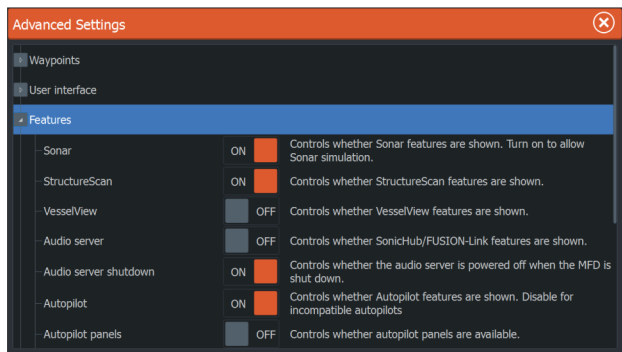

Alarms

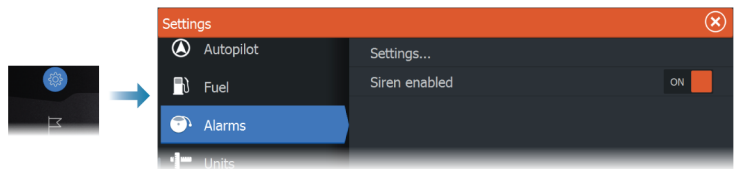

Settings

List of all available alarm options in the system, with current settings.

From this list you can activate, deactivate and change alarm limits.

Siren enable

The Siren enabled option must be set in order for the unit to activate the buzzer when an alarm condition arises.

Its setting also determines the operation of the external alarm output.

Sonar settings

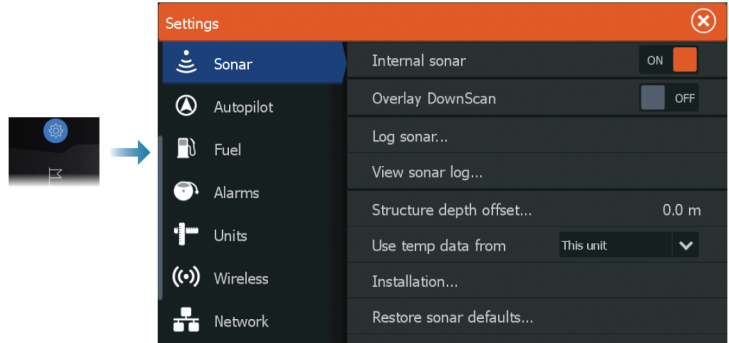

Internal sonar

Used for making the internal sonar available for selection in the sonar panel menu.

When de-activated, the internal sonar will not be listed as a sonar source for any unit on the network.

De-activate this option on units which do not have a transducer connected.

Overlay DownScan

When a DownScan capable transducer is connected to your system, you can overlay DownScan images on the regular Sonar image.

When overlay DownScan is activated, the Sonar panel menu expands to include basic DownScan options.

Structure depth offset

Setting for Structure transducers.

All transducers measure water depth from the transducer to the bottom. As a result, water depth readings do not account for the

distance from the transducer to the lowest point of the boat in the water or from the transducer to the water surface.

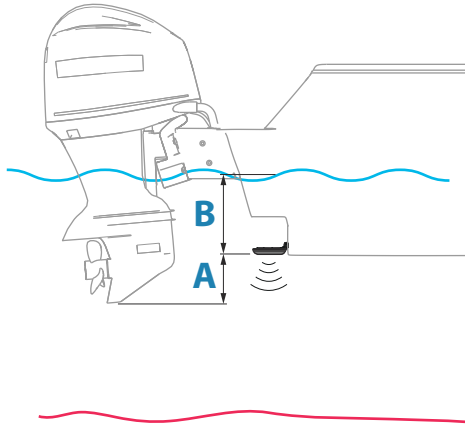

- To show the depth from the lowest point of the vessel to the bottom, set the offset equal to the vertical distance between the transducer and the lowest part of the vessel, **A** (negative value).
- To show the depth from the water surface to the bottom, set the offset equal to the vertical distance between the transducer and the water surface, **B** (positive value)
- For depth below transducer, set the offset to 0.

Use temp data from

Selects from which source the temperature data is shared on the NMEA 2000 network.

Installation

Use this dialog to setup and configure available sources.

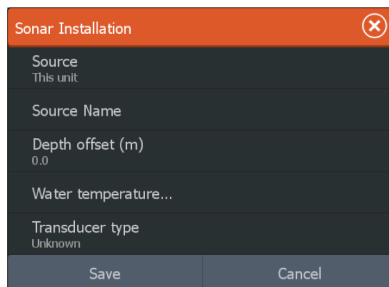

Source

Select this option to display a list of Sonar sources available for setup. The settings you make in the rest of the dialog pertain to the source selected.

Source name

Select this option to set a descriptive name for the selected transducer.

Fishing mode

This feature consists of preset packages of sonar settings designed for specific fishing conditions.

→ **Note:** Selecting the proper fishing mode is critical to optimal sonar performance.

Fishing mode	Depth	Palette
General Use	≤ 1,000 ft	White background
Shallow Water	≤ 60 ft	White background
Fresh Water	≤ 400 ft	White background
Deep Water	≤ 5,000 ft	Deep Blue
Slow Trolling	≤ 400 ft	White background
Fast Trolling	≤ 400 ft	White background
Clear Water	≤ 400 ft	White background
Ice Fishing	≤ 400 ft	White background

Depth offset

All transducers measure water depth from the transducer to the bottom. As a result, water depth readings do not account for the distance from the transducer to the lowest point of the boat in the water or from the transducer to the water surface.

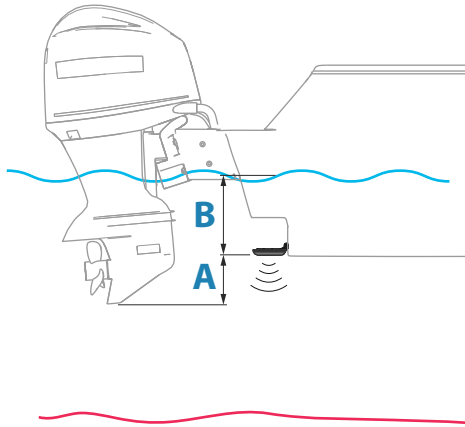

- To show the depth from the lowest point of the vessel to the bottom, set the offset equal to the vertical distance between the transducer and the lowest part of the vessel, **A** (negative value).
- To show the depth from the water surface to the bottom, set the offset equal to the vertical distance between the transducer and the water surface, **B** (positive value)
- For depth below transducer, set the offset to 0.

Water temperature calibration

Temperature calibration is used to adjust the water temperature value from the sonar transducer. It may be required to correct for localized influences to the measured temperature.

Calibration range: -9.9° - $+9.9^{\circ}$. Default is 0° .

→ **Note:** Water temperature calibration only appears if the transducer is temperature capable.

Transducer type

→ **Note:** The transducer type is automatically set for transducers that support Transducer ID (XID) and is not user selectable.

Transducer type is used for selecting the transducer model connected to the sonar module. The transducer selected will determine what frequencies the user can select during sonar operation. In some transducers with built-in temperature sensors, the temperature reading may be inaccurate or not available at all if the wrong transducer is selected. Transducer temperature sensors are one of two impedances - 5k or 10k. Where both options are

given for the same model transducer, refer to paperwork supplied with transducer to determine impedance.

Autopilot settings

Autopilot features will be enabled when a compatible trolling motor is connected. No special setup is required. See the operator manual for further details.

Fuel settings

The fuel utility monitors a vessel's fuel consumption. This information is totaled to indicate trip and seasonal fuel usage, and is used to calculate fuel economy for display on instrument pages and the data bar.

To use the utility, a Navico Fuel Flow sensor, or a NMEA 2000 engine adaptor cable/gateway with Navico Fuel Data Storage device must be fitted to the vessel. The Navico Fuel Flow sensor, does not require the use of a separate Fuel Storage device. Refer to the engine manufacturer or dealer for information on whether or not your engine provides a data output, and what adaptor is available to connect to NMEA 2000.

Once the physical connection is made, ensure source selection is completed. Multiple engine installations using Fuel Flow sensors, or Fuel Data Storage devices, require setup of related engine location in the Device list. For general source selection information, refer to *"Network settings"* on page 37.

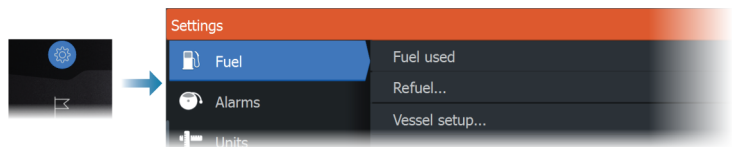

Vessel setup

The Vessel setup dialog must be used to select the number of engines, the number of tanks and vessel's total fuel capacity across all tanks.

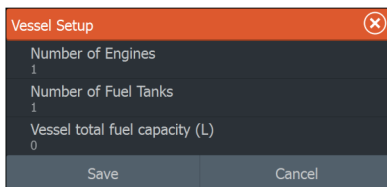

Fuel remaining measurement

The Fuel remaining measurement can be determined from fuel used by engine(s), or fuel level from tank sensors. Nominal fuel consumption is required to set the scale on the fuel economy gauge. This value should be determined from experience, over time. Alternatively the boat builder or designer may be able to give an approximate value to use.

- **Note:** Fuel remaining measurement taken from level sensors while underway can get inaccurate readings due to vessel movement.
- **Note:** Nominal fuel consumption setting should be determined taking into account typical vessel loads. That is, filled fuel and water tanks, stowed tender, supplies, etc.

Fuel flow configuration

After the number of engines is set, it is required to set which fuel flow sensor is connected to which engine. Under Device list on the Network page, view the Device Configuration dialog for each sensor, and set the Location to match the engine the device is connected to.

Unconfigure - defaults the device which clears all user settings.

Reset Fuel Flow - restores only the Fuel K-Value setting, if set in Calibrate. Only Navico devices can be reset.

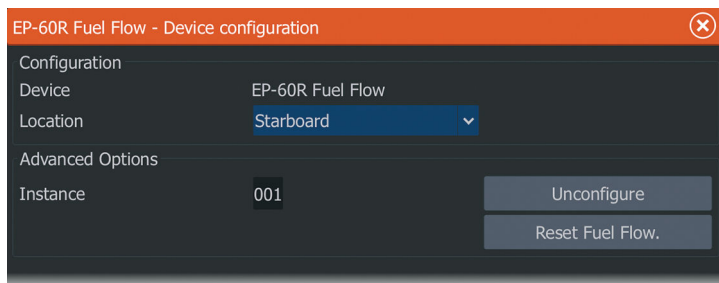

Calibrate

Calibration may be required to accurately match measured flow with actual fuel flow. Access calibration from the Refuel dialog. Calibration is only possible on Navico's Fuel Flow sensor.

1. Start with a full tank and run the engine as it would normally be operated.
 2. After at least several liters (a few gallons) have been used, the tank should be fully refilled, and the Set to full option selected.
 3. Select the Calibrate option.
 4. Set the actual amount used based on amount of fuel added to the tank.
 5. Select OK to save settings. The Fuel K-Value should now show a new value.
- **Note:** To calibrate multiple engines repeat the steps above, one engine at a time. Alternatively, run all engines simultaneously, and divide the Actual amount used by the number of engines. This assumes reasonably even fuel consumption on all engines.
- **Note:** The Calibrate option is only available when Set to full is selected, and a Fuel Flow is connected and set up as a source.
- **Note:** A maximum of 8 engines is supported using Fuel Flow sensors.

Fuel Level

With the use of a Navico Fluid Level device connected to a suitable tank level sensor, it is possible to measure the amount of fuel remaining in any equipped tank. The number of tanks must be set in Vessel Setup dialog, initiated from the Fuel setting options page, to allow discrete tank assignment of the Fluid Level devices.

Select Device list on the Network page, and view the Device Configuration dialog for each sensor, and set the Tank location, Fluid type, and Tank size.

For setting up the Instrument bar or a gauge on the Instrument page with Fluid Level device data, refer to the Operator Manual.

- **Note:** A maximum of 5 tanks is supported using Fluid Level devices.

→ **Note:** Tank data that is output by a compatible engine gateway can also be displayed, however tank configuration for such a data source is not possible from this unit.

Wireless settings

Provides configuration and setup options for the wireless functionality.

For further details about wireless setup and connectivity, refer to the Operator Manual.

WiFi connectivity

The unit can act both as a WiFi access point and as a WiFi client at the same time. The unit can only act as one access point and one client simultaneously.

The unit acts as an access point when:

- a phone or tablet is connected for remote control of the unit
- the unit is the base unit for connection with another Elite Ti²

The unit acts as a client when:

- connected to a WiFi network
- connected to another Elite Ti² acting as the base

Connect with another Elite Ti²

Select to connect to another Elite Ti² unit. Prompts will guide you through the pairing.

When paired the units can share:

- sonar (not SideScan or DownScan)
- chart cards
- waypoints and routes



Network settings

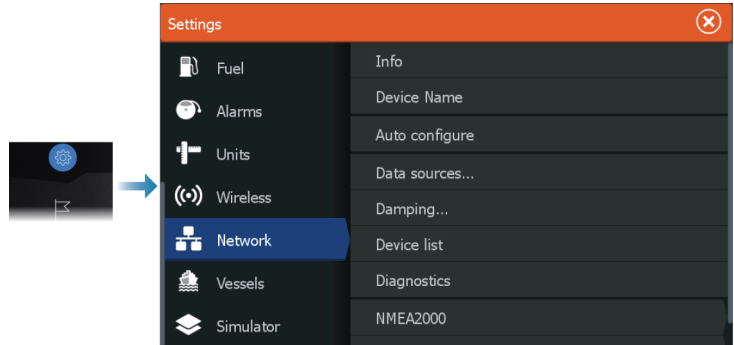

Network info

Lists basic network information.

Device name

Assigning a name is useful in systems using more than one device of the same type and size.

Auto configure

The auto configure option looks for all sources connected to the device. If more than one source is available for each data type, selection is made from an internal priority list.

→ **Note:** This option provides the best configuration of available data sources for the majority of installations.

Data sources

Data sources provide live data to the system. When a device is connected to more than one source providing the same data, the user can choose the preferred source.

Before commencing with source selection make sure all external devices and networks are connected and turned on. Manual selection is generally only required where there is more than one source for the same data, and the automatically selected source is not the one desired.

Damping

If data appears erratic or too sensitive, damping may be applied to make the information appear more stable. With damping set to off, the data is presented in raw form with no damping applied.



Device list

Selecting a device in this list will bring up additional details and options for the device.

All devices allow allocation of an instance number in the configure option. Set unique instance numbers on any identical devices on the network to allow the unit to distinguish between them. The data option shows all data being output by the device. Some devices will show additional options specific to the device.

→ **Note:** Setting the instance number on a 3rd party product is typically not possible.

Diagnostics

Provides information useful for identifying an issue with the network.

NMEA 2000

Provides information on NMEA 2000-bus activity.

→ **Note:** The following information may not always indicate an issue that can be simply resolved with minor adjustment to network layout or connected devices and their activity on the network. However, Rx and Tx errors are most likely indicating issues with the physical network, which may be resolved by

correcting termination, reducing backbone or drop lengths, or reducing the number of network nodes (devices).

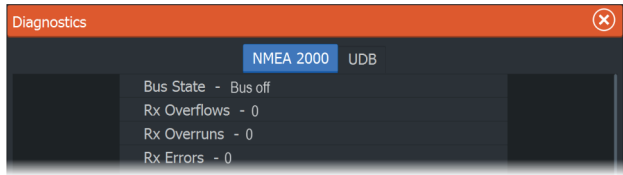

UDB

Provides information on Ethernet activity.

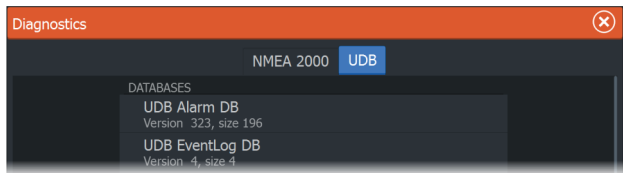

NMEA 2000 setup

Receive waypoint

Select this option to allow another device capable of creating and exporting waypoints via NMEA 2000 to transfer directly to this unit.

Send waypoint

Select this option to allow this unit to send waypoints to another device via NMEA 2000.

→ **Note:** The system can only transmit or receive one waypoint at a time on creation of that waypoint. For bulk import or export of waypoints see the operator manual.

Backlight synchronization

Select this option to allow display brightness synchronization across display units connected to the same network.

NMEA 0183 setup

The NMEA 0183 port(s) must be set to suit the speed of connected devices, and can be configured to output only the sentences required by listening devices.

Receive waypoint

Select this option to allow a device capable of creating and exporting waypoints via NMEA 0183 to transfer directly to this unit.

Serial ports

Specifies the baud rate and protocol for the NMEA 0183 interface. The baud rate should be set to correspond with devices connected to the NMEA 0183 input and output.

Serial output

Selection determines whether the data is output via Tx lines, and will enable editing of the output sentences list.

Serial output sentences

This list allows control over which sentences that are transmitted to other devices from the NMEA 0183 port. Due to the limited bandwidth of NMEA 0183 it is desirable to only enable the data that is required. The less sentences that are selected, the higher the output rate of the enabled sentences.

Commonly used sentences are enabled by default.

Wireless

The NMEA 0183 data stream is output and made available to tablet devices and PCs, via the internal wireless. The dialogue provides IP and port data typically required for configuring the application on the third party device.

→ **Note:** Other MFDs cannot decode this information back to NMEA 0183, to use the data as a source. To share data a physical NMEA 2000 or NMEA 0183 connection is still required.

5

3rd party support

SmartCraft VesselView integration

When a compatible Mercury Marine VesselView product or VesselView Link is present on the NMEA 2000 network, the engines can be monitored and controlled from the unit.

When the feature is also enabled in the advanced settings features dialog:

- A Mercury icon is added to the home page - select it to display the engine instrument panel.
- A Mercury settings dialog is added - use this dialog to change engine settings.
- Mercury and Vessel Control buttons are added to the control bar:
 - Selecting the Mercury button displays engine and vessel data.
 - Selecting the Vessel button opens the engine controller.

When the features are enabled, the display may prompt the user for some basic configuration information.

For more information, refer to the VesselView manual or engine supplier.

Suzuki engine integration

If a Suzuki C-10 gauge is available on the NMEA 2000 network, the engines can be monitored from the unit.

When the feature is also enabled in the advanced settings features dialog:

- A Suzuki icon is added to the home page - select it to display the engine instrument panel.

For more information, refer to the engine manual or engine supplier.

Yamaha engine integration

If a compatible Yamaha gateway is connected to the NMEA 2000 network, the engines can be monitored from the unit.

When the feature is also enabled in the advanced settings features dialog:

- A Yamaha icon is added to the home page - select it to display the engine instrument panel.
- If the Yamaha system supports Troll Control, a Troll button is added to the Control Bar. Select this button to enable/disable troll control and control the trolling speed.

For more information refer to the engine manual or the engine supplier.

Evinrude engine integration

If an Evinrude engine control head is available on the NMEA 2000 network, the Evinrude engines can be monitored and controlled from the unit.

When the feature is also enabled in the advanced settings features dialog:

- An Evinrude icon is added to the home page - select it to display the engine instrument panel.
- An Evinrude settings dialog is added - use this dialog to change engine settings.
- An Evinrude button is added to the control bar - selecting this button opens the engine controller. Use the engine controller to control the engines.

A maximum of two control heads and four engines is supported.

For more information, refer to the engine manual or engine supplier.

Power-Pole anchors

Power-Pole anchors, which can be controlled by the C-Monster Control System installed on your boat, can be controlled from the unit. To control the Power-Poles, you pair the Power-Poles with the unit using Bluetooth wireless technology available in both products.

6

Accessories

The most up-to-date accessories list is available at:

7

Supported data

NMEA 2000 compliant PGN List

NMEA 2000 PGN (receive)

59392	ISO Acknowledgement
59904	ISO Request
60928	ISO Address Claim
61184	Parameter Request/Command
65285	Temperature with Instance
65289	Trim Tab Insect Configuration
65291	Backlight Control
65292	Clear Fluid Level Warnings
65293	LGC-2000 Configuration
65323	Data User Group Request
65325	Reprogram Status
65341	Autopilot Mode
65480	Autopilot Mode
126208	ISO Command Group Function
126992	System Time
126996	Product Info
127237	Heading/Track Control
127245	Rudder
127250	Vessel Heading
127251	Rate of Turn
127257	Attitude
127258	Magnetic Variation
127488	Engine Parameters, Rapid Update
127489	Engine Parameters, Dynamic
127493	Transmission Parameters, Dynamic
127503	AC input status

127504 AC Output Status
127505 Fluid Level
127506 DC Detailed Status
127507 Charger Status
127508 Battery Status
127509 Inverter Status
128259 Speed, Water referenced
128267 Water Depth
128275 Distance Log
129025 Position, Rapid Update
129026 COG & SOG, Rapid Update
129029 GNSS Position Data
129033 Time & Date
129038 AIS Class A Position Report
129039 AIS Class B Position Report
129040 AIS Class B Extended Position Report
129041 AIS aids to Navigation
129283 Cross Track Error
129284 Navigation Data
129539 GNSS DOPs
129540 AIS Class B Extended Position Report
129794 AIS aids to Navigation
129801 Cross Track Error
129283 Cross Track Error
129284 Navigation Data
129539 GNSS DOPs
129540 GNSS Sats in View
129794 AIS Class A Static and Voyage Related Data
129801 AIS Addressed Safety Related Message
129802 AIS Safety Related Broadcast Message
129808 DSC Call Information
129809 AIS Class B "CS" Static Data Report, Part A

129810 AIS Class B "CS" Static Data Report, Part B
130074 Route and WP Service - WP List - WP Name & Position
130306 Wind Data
130310 Environmental Parameters
130311 Environmental Parameters
130312 Temperature
130313 Humidity
130314 Actual Pressure
130576 Small Craft Status
130577 Direction Data
130840 Data User Group Configuration
130842 SimNet DSC Message
130845 Parameter Handle
130850 Event Command
130851 Event Reply
130817 Product Info
130820 Reprogram Status
130831 Suzuki Engine and Storage Device Config
130832 Fuel Used - High Resolution
130834 Engine and Tank Configuration
130835 Set Engine And Tank Configuration
130838 Fluid Level Warn
130839 Pressure Insect Configuration
130840 Data User Group Config
130842 AIS and VHF Message Transport
130843 Sonar Status – Frequency and DSP Voltage
130845 Weather and Fish Prediction and Barometric Pressure History
130850 Evinrude Engine Warnings
130851 Parameter (RC42 Compass and IS12 Wind Calibration and Configuration)

NMEA 2000 PGN (transmit)

61184	Parameter Request/Command
65287	Configure Temperature Insects
65289	Trim Tab Insect Calibration
65290	Paddle Wheel Speed Configuration
65291	Backlight Control
65292	Clear Fluid Level Warnings
65293	LGC-2000 Configuration
65323	Data User Group Request
126208	ISO Command Group Function
126992	System Time
126996	Product Info
127237	Heading/Track Control
127250	Vessel Heading
127258	Magnetic Variation
128259	Speed, Water referenced
128267	Water Depth
128275	Distance Log
129025	Position, Rapid Update
129026	COG & SOG, Rapid Update
129029	GNSS Position Data
129283	Cross Track Error
129284	Navigation Data
129285	Route/Waypoint Data
129539	GNSS DOPs
129540	GNSS Sats in View
130074	Route and WP Service - WP List - WP Name & Position
130306	Wind Data
130310	Environmental Parameters
130311	Environmental Parameters

- 130312 Temperature
- 130577 Direction Data
- 130840 Data User Group Configuration
- 130845 Parameter Handle
- 130850 Event Command
- 130818 Reprogram Data
- 130819 Request Reprogram
- 130828 Set Serial Number
- 130831 Suzuki Engine and Storage Device Config
- 130835 Set Engine And Tank Configuration
- 130836 Fluid Level Insect Configuration
- 130837 Fuel Flow Turbine Configuration
- 130839 Pressure Insect Configuration
- 130845 Weather and Fish Prediction and Barometric Pressure History
- 130850 Evinrude Engine Warnings
- 130851 Parameter (RC42 Compass and IS12 Wind Calibration and Configuration)

NMEA 0183 supported sentences

TX / RX - GPS

Receive	GGA	GLL	GSA	GSV	VTG	ZDA	
Transmit	GGA	GLL	GSA	GSV	VTG	ZDA	GLC

TX / RX - Navigation

Receive	RMC				
Transmit	AAM	APB	BOD	BWC	BWR

Receive					
Transmit	RMC	RMB	XTE	XDR	

TX / RX - Sonar

Receive	DBT	DPT	MTW	VLW	VHW
Transmit	DBT	DPT	MTW	VLW	VHW

TX / RX - Compass

Receive	HDG	HDT	HDM
Transmit	HDG		

TX / RX - Wind

Receive	MWV	MWD
Transmit	MWV	MWD

TX / RX - AIS / DSC

Receive	DSC	DSE	VDM
----------------	-----	-----	-----

→ **Note:** AIS sentences are not bridged to or from NMEA 2000.

8

Technical specifications

Elite Ti²

Display	
Resolution	480 x 800
Brightness	>1200 nits
Touch screen	Single touch
Viewing angles in degrees (typical value at contrast ratio = 10)	50° top, 60° bottom, 70° left/ right
Electrical	
Supply voltage	12 V DC (10 - 17 V DC min - max)
Power consumption - Max	
7" unit	12 W (0.9 A at 13.8 V DC)
9" unit	12 W (0.9 A at 13.8 V DC)
12" unit	22 W (1.6 A at 13.8 V DC)
Recommended fuse rating	
7" unit	6 A at 12 V DC / 3 A at 24 V DC
9" unit	7 A at 12 V DC / 4 A at 24 V DC
12" unit	10 A at 12 V DC / 5 A at 24 V DC
Environmental	
Operating temperature range	-15°C to +55°C (5°F to 131°F)
Storage temperature	-20°C to +60°C (4°F to 140°F)
Waterproof rating	IPX6 and IPX7
Humidity	IEC 60945 Damp heat 66°C (150°F) at 95% relative (48 hr)
Shock and vibration	100 000 cycles of 20 G
Interface/Connectivity	
NMEA 2000	1x (Micro-C)
NMEA 0183	1 port (via the power connector)
Data card reader	1x slot (microSD)

Wireless	Internal 802.11b/g/n
Physical	
Dimensions (W x H x D)	Refer to "Dimensional drawings" on page 53
Weight (display only)	
7" unit	0.91 kg (2.0 lbs.)
9" unit	1.32 kg (2.9 lbs.)
12" unit	2.2 kg (4.9 lbs.)
Compass Safe Distance - Metric, imperial	50 cm
Mounting type	Panel mount or bracket mount

9

Dimensional drawings

ELITE 7Ti²

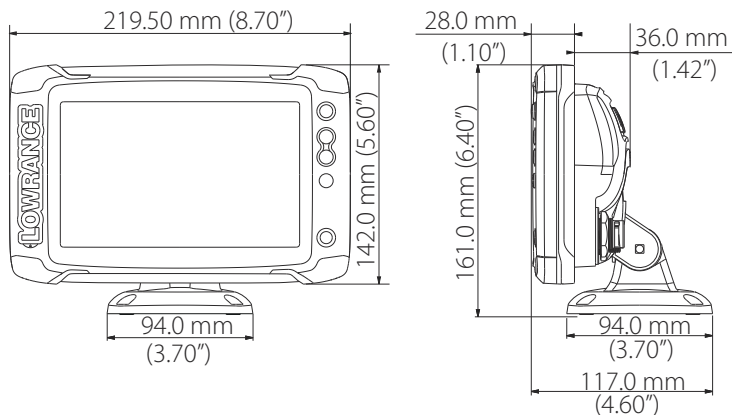

ELITE 9Ti²

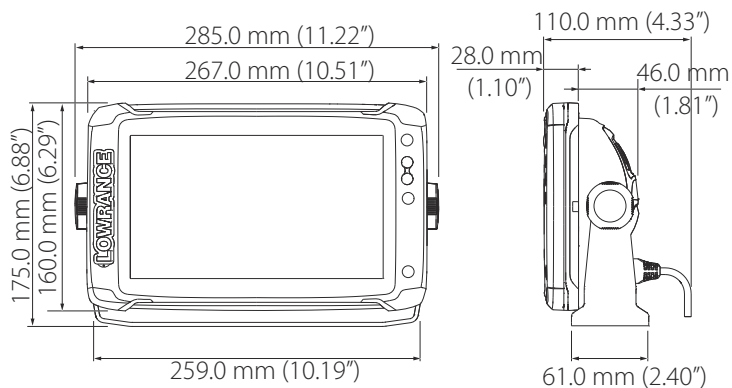

ELITE 12Ti²

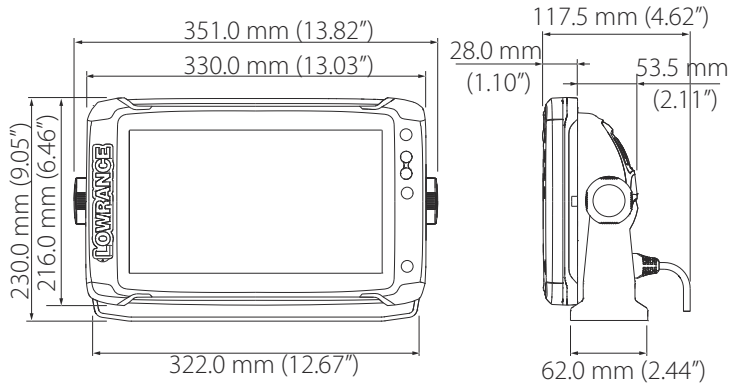



LOWRANCE®